

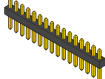

Small Displays (16 x 2 LCD Display)



The Pieces

-  **Liquid Crystal Display x1**
-  **16 Pin Header x1**
-  **Potentiometer (10k Ohm) x1**

The Schematic

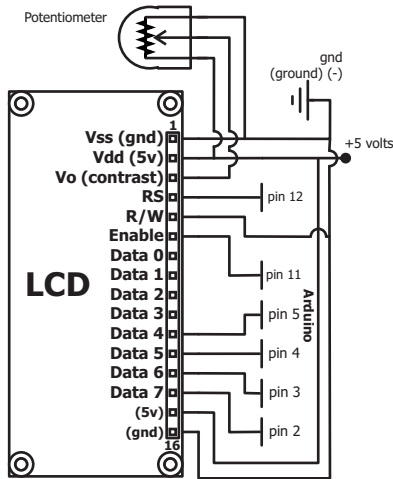

The Theory & Code

Liquid Crystal Displays (LCD)

An LCD is a small low cost display. It is easy to interface with a micro-controller because of an embedded controller (the black blob on the back of the board). This controller is standard across many displays (HD 44780) which means many micro-controllers (including the Arduino) have libraries that make displaying messages as easy as a single line of code.

Assembling

To get started you'll need to attach the header pins to your LCD module, learn how to do this at: <http://sparkfun.com/lcd>

Testing

Testing your LCD with an Arduino is really simple. Wire up your display using the schematic or breadboard layout sheet. Then open the Arduino IDE and open the example program.

File > Examples > LiquidCrystal > HelloWorld

Upload to your board and watch as "hello, world!" is shown on your display. If no message is displayed the contrast may need to be adjusted. To do this turn the potentiometer.

Library Summary

(here's a summary of the LCD library for a full reference visit <http://ardx.org/LCD-REF>)

- LiquidCrystal(rs, rw, enable, d4, d5, d6, d7) - create a new LiquidCrystal object using a 4 bit data bus
- LiquidCrystal(rs, rw, enable, d0, d1, d2, d3, d4, d5, d6, d7) - create a new LiquidCrystal object using an 8 bit data bus
- clear() - Clears the display and moves the cursor to upper left corner
- home() - Moves the cursor to the upper left corner
- setCursor(col, row) - moves the cursor to column col and row row
- write(data) - writes the char data to the display
- print(data) - prints a string to the display

Technical Details

∴ Full LCD Datasheet: <http://ardx.org/LCD-DATAS> ∴

The Circuit

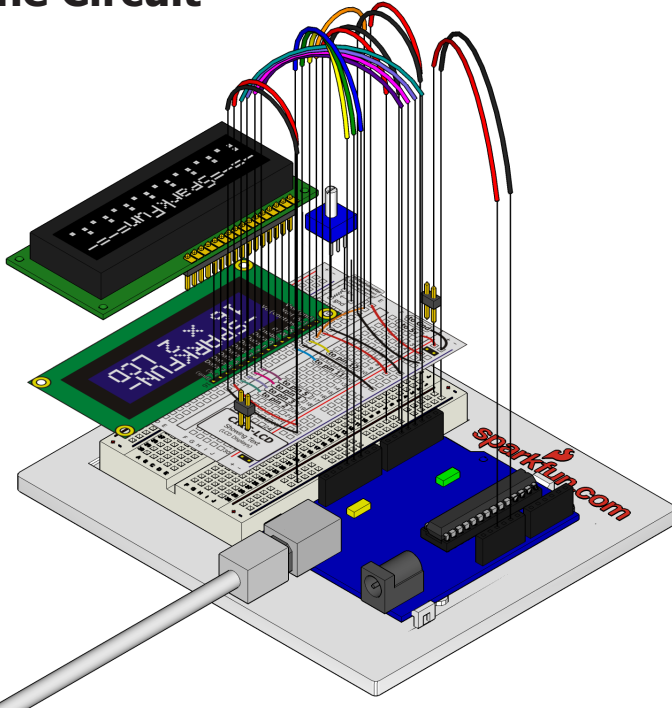

∴ **Instructions:** print out, cut out, get making ∴
∴ for more details visit: <http://ardx.org/CIRC-LCD> ∴

The Layout Sheet

