

IMU 6 Degrees of Freedom v4 Data Sheet

1 Overview

The 6DOF v3 gets a make-over!

The 6DOF v4 Inertial Measurement Unit (IMU) is the newest SparkFun IMU offering, bringing the best features of the v3, plus a few new functions inspired by customer feedback and suggestions.

The v4 provides 3 axes of acceleration data, 3 axes of gyroscopic data, and 3 axes of magnetic data. Each independent channel is user selectable, as is the sampling frequency. The device can also report in ASCII or binary format, and can work over a Bluetooth link or a TTL hardline. Control is provided through an LPC2138 ARM7 processor with plenty of extra memory for custom code development. Additionally, the code has been ported to the WinARM development platform. With the freely available source code, you can be doing your own development in minutes!

The IMU 6-DOF v4 uses these sensors:

- Freescale MMA7260Q triple-axis accelerometer, settable to 1.5 g, 2 g, 4 g or 6 g sensitivity
- 2 InvenSense IDG500 500 degree/second gyros
- Honeywell HMC1052L and HMC1051Z magnetic sensors

All sensor readings are available through any terminal program in either ASCII or binary format, or with the improved 6DOF v4 IMU Mixer demo application (source code also available). Additionally, all sensors are internally temperature compensated.

2 Electrical Specs

- Input voltage: 4.2V to 7V DC
- Current consumption: less than 150mA
- Frequency response:
 - Magnetic sensors: 312Hz
 - IDG500 Gyros: 140Hz
 - MMA7260Q Accelerometer:
 - 350Hz, X and Y axes
 - 150Hz, Z axis

For a full description of the sensor specifications, please see the respective manufacturer's data sheets ([available at www.Sparkfun.com](http://www.Sparkfun.com)).

3 Hardware Overview

Like the v3, the v4 is a double-decker unit with the controller board on the bottom and the sensor board on the top. Each board has its own 3.3V regulator in order to better separate the digital and analog circuits.

3.1 Controller Board

There are a few things that the user may want to familiarize themselves with regarding the controller board.

Figure 1: Controller Board

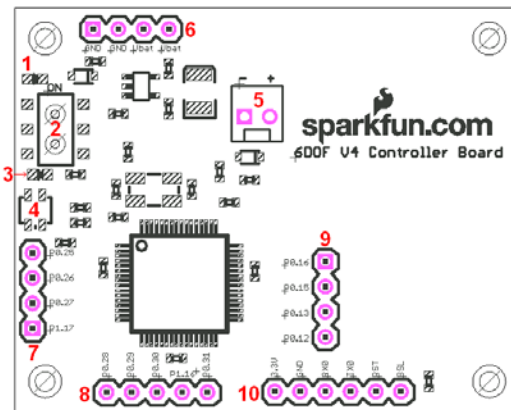

- 1) Power indicator LED
- 2) Power switch
- 3) Bluetooth connection indicator LED
- 4) Tri-color status LED
- 5) Power connector
- 6) Power port for sensor board, switched from controller board
- 7) Magnetic sense lines
- 8) Accelerometer sense lines
- 9) Gyro sense lines
- 10) Programming port and TTL serial line

To aid in custom development, we've indicated the individual port numbers of the LPC2138 processor to which the user has access. All ADC lines are 0V to 3.3V, 10-bit. For a more in depth description of the LPC2138's capabilities, please see the LPC2138 User's manual.

3.2 Sensor Board

There are a few things that the user may want to familiarize themselves with regarding the controller board.

As stated previously, the sensor board uses Honeywell HMC1052L and HMC1051Z magnetic sensors. We've also included set/reset circuitry (used for realigning each sensor's magnetic domains

Figure 2: Sensor Board

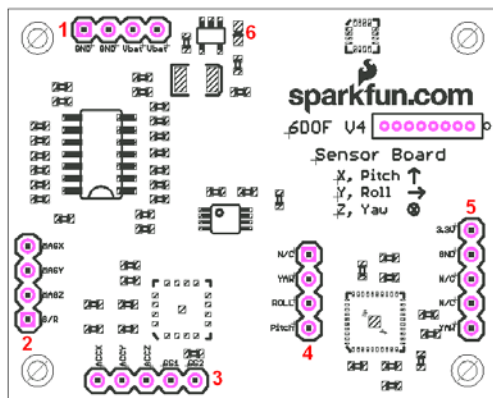

- 1) Power port
- 2) Magnetic sense lines, plus ser/reset line
- 3) Acceleration sense lines, plus range set lines
- 4) Gyro sense lines
- 5) Vertical-mount gyro port
- 6) Power indicator LED

before each measurement), and each channel of the magnetic sensors has a high-gain differential amplifier as suggested by the HMC105X documentation. Supporting components have been kept at a distance from the sensors so as to increase the accuracy of the measurements.

The MMA7260Q accelerometer and the IDG500 gyros have each been set up per their manufacturer's recommendations, i.e. internal clock suppression filters on their outputs. These sensors are also internally temperature compensated.

All of the sensor lines have been indicated on the PCB should the user wish to use the 6DOF v4 sensor board with another control system, and all analog outputs are 0V to 3.3V.

4 Setup

When you first power up the 6DOF v4, you will see the power indicator LEDs on both the controller board and the sensor board light up. You will also see the tri-color status LED flash a few times. During normal sampling operations, the status LED will toggle red-blue-green, each color for 64 sample frames. When in the configuration menu, all colors will be on. If the device is not in the configuration menu and not sampling, the 6DOF is in its idle state and the status LED will be off (see the section on the configuration menu auto run mode for more details on this).

The 6DOF v4 comes pre-configured to run over Bluetooth. But if you haven't got a Bluetooth module...

4.1 Hard line connection

We've provided a back-door to get into the configuration over the hard line, but first the user needs to establish a hardware connection. The easiest way is to use one of our LPC programming adapters PGM-00714 or PGM-08650, but the user will still need to either solder a female header or the programming adapter itself to the 6DOF v4. We suggest using a header, but if you should choose to solder directly take care to get the orientation correct.. All of the signal lines are printed on the respective PCB's, so all you need to do is line them up.

If you should choose another means of hardware connection, you will need to know that the 6DOF v4 controller board TX and RX lines are 0 to 3.3V, not 5V, and certainly not RS-232. If you connect the controller board directly to an RS-232 line, you will likely damage the board.

From this point, we will assume that the user has provided for the hardware connection and we'll continue with the setup. Load your battery pack and plug it in to the 6DOF (or otherwise apply power to the device). Start with your 6DOF off but connected to your serial line. Open up a terminal program (Hyperterminal, Teraterm, etc) to the port to which you're connected with settings of 115,200 baud, 8 data bits, one stop bit, no parity or flow control. Now simultaneously hold down the spacebar on your keyboard and turn the 6DOF on. You should see the configuration menu come up (it will likely scroll past a few times since the keyboard repeats). Release the spacebar and choose option 6 to toggle the output port to "serial TTL". Cycle power for the setting to take effect.

4.2 Bluetooth connection

Generally speaking, a Bluetooth discovery will show the 6DOF v4 as "Firefly" with a random MAC. If you're using a Bluetooth device other than what is available from SparkFun, connect to the 6DOF v4 according to that manufacturer's directions as a serial port.

If you're using one of the Roving Networks Bluetooth devices available through SparkFun, you can directly open a serial port to the local device and issue discovery and connection commands without the interference of third-party Bluetooth drivers or other supporting software.

The first thing to do is to load your battery pack, plug it into your 6DOF v4 and turn it on. Assuming the user has a Roving Networks Bluetooth dongle (like the BlueDongle-RN-USB), the setup is very simple. Plug in your dongle and open a terminal program to the correct port, set to the same settings mentioned previously (115,200 baud, etc.). Issue the command "\$\$\$<enter>" and the dongle will answer back with "CMD?". Then enter the command "l<enter>" and the dongle will go off and search for other Bluetooth devices for a few seconds. When it's done, it will report to you how many devices it found and give you their names and MAC addresses. The 6DOF v4 will show up as "Firefly" with a random MAC address. Now enter the command "C,<MAC address><enter>", where <MAC address> is that of the 6DOF v4, and the dongle will answer back with

“Trying”. The dongle won’t report the successful connection with text in the terminal window, but you’ll see the connection indicator LED light up on both the 6DOF and the dongle. Now you’re connected and ready to run.

4.3 6DOF v4 Mixer demo application

For a demonstration of the 6DOF v4’s operation, the user can run the 6DOF v4 Mixer program. With the 6DOF powered up and connected in its idle state, close any terminal programs, open the 6DOF’s serial port and start the mixer application. Select the port number to which the 6DOF is connected, set the frequency and sensitivity, hit the start button and you’re off and running.

The mixer program requires that all channels are active. If you have any trouble getting the program to work right, check that all channels are active in the configuration menu.

5 Using a Terminal and the Configuration Menu

Once the novelty of the mixer program wears off, the user may want to do something slightly more useful with the v4, like attach it to something and log a file with a terminal program. What follows is a description of the configuration menu as well as a functional description of the v4’s operation.

5.1 Operation from the Idle State

Upon reset and in its default configuration, the v4 will check to see if it has been configured for “auto run” mode (more on that later). If it’s not in auto run mode, it goes into an idle state waiting for input. Normally this idle state serves as the start up state for the mixer application. In this state, the following inputs have the following effects:

- 1) “%”, ASCII 37, sets the accelerometer to 1.5 g sensitivity
- 2) “&”, ASCII 38, sets the accelerometer sensitivity to 2 g
- 3) “ ’ ” (apostrophe), ASCII 39, sets the accelerometer sensitivity to 4 g
- 4) “ (“, ASCII 40, sets the accelerometer sensitivity to 6 g
- 5) “) ”, ASCII 41, sets the sample frequency to 50Hz
- 6) “ * ”, ASCII 42, sets the sample frequency to 100Hz
- 7) “ + ”, ASCII 43, sets the sample frequency to 150Hz
- 8) “ , “, ASCII 44, sets the sample frequency to 200Hz
- 9) “ - “, ASCII 45, sets the sample frequency to 250Hz
- 10) “ . ”, ASCII 46, sets the sample frequency to 300Hz
- 11) “ # ”, ASCII 35, starts the unit running in binary mode with all channels active
- 12) “ ” (space), ASCII 32, stops the unit and returns it to the idle state (issuing another ASCII 32 will bring up the configuration menu)

Operation from this idle state will always be in binary output mode, but the user may select which channels are active. Also, configuration from this state as done in the mixer application will not be saved

in memory, whereas settings from the actual configuration menu will be saved to memory for future use. At the same time, all but the active channel settings saved in memory have no effect on operation from the idle state. It should be noted that the primary purpose of this idle state and mode of operation is to more easily interact with the v4 mixer demonstration application, but there’s no reason that a user’s own application couldn’t use it for a quick setup. It should also be noted that the 300Hz sampling rate is not available from the mixer app’s selection, the reason being that the Bluetooth begins to exhibit latency when streaming data into it at somewhere between 250Hz and 300Hz with all channels active. But the 300Hz option is available from the idle state in case the user wishes to try it. Of course, operation from the configuration menu has no maximum setting (more on that later).

5.2 Operation from the Configuration Menu

To use the v4 from a terminal program, start up your program of choice (115,200 baud, hardware flow control, 8 data bits, one stop bit, no parity), plug in your Blue Dongle and power up your v4. When the devices connect, the Blue Dongle will report the connection established back to you. The v4 is now in the aforementioned idle state. Pressing the spacebar will bring up the configuration menu (STAT0 and STAT1 will come on as well), and here’s what you’ll see:

```
6DOF v4 setup, version 1.0
  1) View/edit active channel list
  2) Change output mode, currently binary
  3) Set Auto run mode, currently off
  4) Set accelerometer sensitivity, currently 1.5 g
  5) Set output frequency, currently 100
  6) Change output port, currently Bluetooth
  9) Save settings and run unit
```

5.3 Active Channel List

Pressing “1” will bring up the active channel list:

```
  1) Magneto X = on
  2) Magneto Y = on
  3) Magneto Z = on
  4) Accel X = on
  5) Accel Y = on
  6) Accel Z = on
  7) Pitch = on
  8) Roll = on
  9) Yaw = on
```

Press the number of the channel you wish to change, or press x to exit.

To change a channel from active to inactive (or the reverse), just press the number of the channel you wish to change. It’s a toggling

function; pressing a number will bring up the full list again, but with the channel you wished to change in its opposite state. Press a few numbers and get a feel for it. Pressing “x” gets you back to the main menu.

5.4 Output Mode

Pressing “2” from the main menu will toggle the output mode from binary to ASCII and back again. What are these output modes, you ask?

In both output modes, the data from all active channels is framed by an “A” (ASCII 65) at the start and a “Z” (ASCII 90) at the end. Also in both modes, each channel is reported in exactly the sequence shown in the active channel list, with the addition of a sample count that immediately follows the “A” and precedes the first active measurement, which is to say:

- 1) Count
- 2) Mag X
- 3) Mag Y
- 4) Mag Z
- 5) Accel X
- 6) Accel Y
- 7) Accel Z
- 8) Pitch
- 9) Roll
- 10) Yaw

The count is two bytes that comes as MSB-LSB, and will range from 0 to 32767. If any of the channels are selected as inactive, that data is omitted from the frame and subsequent data moves up in the report sequence.

In binary mode, each active channel report comes as 2 bytes: MSB and LSB, in that sequence, and they will always be between 0 and 1023 because we’re reading from 10-bit ADC’s. The width of the data frame in binary mode will be 4 bytes (“A”, “Z”, and count are always present) plus 2 bytes for each active measurement. So for all channels active the data frame will be 22 bytes wide.

In ASCII mode, the count and active measurements are reported in ASCII so it’s easier to read with a terminal program, plus all measurements and the count are delimited with TAB characters (ASCII 9) as well as a carriage return and line feed at the end of the data frame. This makes data capture and importation into a spreadsheet a relatively simple matter.

5.5 Auto Run Mode

Pressing “3” from the main menu will toggle the auto run setting. If you intend to use the v4 in ASCII mode, set this to “on”. If the auto run feature is off, the v4 will always run from its primary idle state, which means that it will always wait for a “#” to begin sampling and it will always run in binary mode.

One feature of auto run mode is that if the setting is active the v4 will begin sampling immediately upon power up, or after establishment

of a Bluetooth connection if the Bluetooth is active. Pressing the spacebar will bring up the configuration menu again.

5.6 Setting the Accelerometer Sensitivity

Pressing “4” from the main menu will bring up the following submenu:

Set to:

- 1) 1.5g
- 2) 2g
- 3) 4g
- 4) 6g

Just press the number which corresponds to your choice and the v4 will revert to the main menu with the sensitivity changed.

5.7 Setting the Output Frequency

Pressing “5” from the main menu will allow you to change the sample frequency. Simply press “i” to increase or “d” to decrease, or “x” to revert to the main menu.

The minimum frequency setting is 10Hz, and there is no maximum setting. This allows the user to experiment with smaller data frames and higher sampling rates.

5.8 Setting the output port

Pressing “6” will allow you to toggle the output port, either Bluetooth or serial TTL. After selecting this option, you will be prompted to cycle power for this setting to become active.

5.9 Save Settings and Run Unit

Pressing “9” from the main menu will save the current settings to flash and exit the configuration menu. If the auto run feature has been activated the unit will begin running immediately. If it has not been set, the unit will revert to the initial idle state and wait for additional input.

6 Bandwidth Considerations and Firmware

The 6DOF v4 does not have any filtering in firmware, though there is enough memory left in the LPC2138 flash program space to implement some filtering. The internally set output bandwidth of the MMA7260Q accelerometer is 350Hz for the X and Y axes, and 150Hz for the Z axis. There are also additional single pole low pass filters to reduce switching noise from the sensor with poles set at 1591Hz (recommended by Freescale). The internally set output bandwidth for the IDG300 gyro sensors is 120Hz, along with single pole low pass filters at 96Hz (recommended by InvenSense). The HMC1052L and HMC1051Z magnetic sensors don’t have internal filtering, but each axis has an external single pole low pass filter set at 319Hz. Of course, it’s a good idea for the user to consider these numbers when developing an application to ensure that the proper filtering is in place for whatever sampling rate is selected.



2008.04.22

IMU 6 Degrees of Freedom v4 Data Sheet

All source code and schematics for the 6DOF v4 are freely available from the v4's product description page. Source code is compiled with GCC using WinARM (http://www.siwawi.arubi.uni-kl.de/avr_projects/arm_projects/#winarm). Programming is typically done with the SparkFun LPC programming adapter (SKU #'s: PGM-00714 or PGM-08650) and Flash Magic, which is available for free download at <http://www.flashmagictool.com/>.



© 2007 SparkFun Electronics, Inc. All Rights Reserved. Product features, specifications, system requirements and availability are subject to change without notice. GeoChron is a trademark of SparkFun Electronics, Inc. All other trademarks contained herein are the property of their respective owners.

IMU6-DOF_DS_v4rev1_080422

5/8



IMU 6 Degrees of Freedom v4 Data Sheet

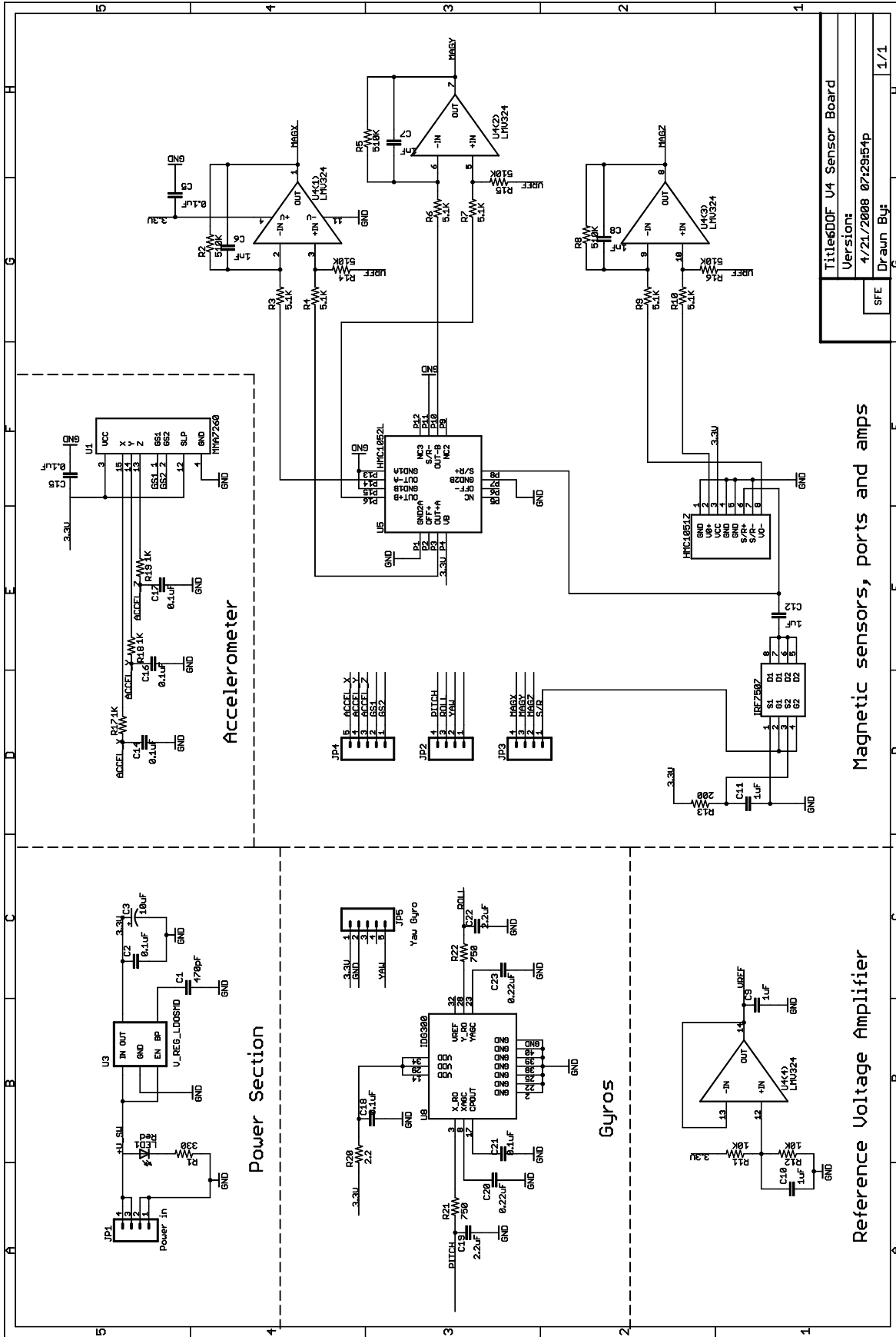

Title: 6DOF V4 Sensor Board	
Version: 4/21/2008 07:29:54p	
SFE	1/1

Magnetic sensors, ports and amps

Reference Voltage Amplifier

