

FIM30xx



NITGEN® FIM30xx

Stand-Alone Fingerprint Identification Device with Built-in CPU

Datasheet

Preliminary

Version 1.05

FIM30xx



© Copyright 2006 NITGEN Co., Ltd.

ALL RIGHTS RESERVED

Serial Number:

Specifications can be changed without notice.

FIM30xx



Revision History

<i>Date of Revision</i>	<i>Version</i>	<i>Description</i>
2006-05-15	1.00	Release
2006-07-11	1.01	FIM3030-HV added
2006-07-25	1.05	FIM3040-LV, FIM3040-HV added

1. General Descriptions

FIM30xx is a low-price stand-alone Fingerprint Identification Device with many excellent features. It provides benefits such as high identification performance, low power consumption and RS-232 serial interface with the various commands for easy integration into a wide range of applications. It is a durable and compact device with fingerprint identification module containing NITGEN® optics-based fingerprint sensor inside.

2. Target Application

- Door-lock system
- Safe Box
- Simple Access Controller
- Vehicle Control
- ATM , POS
- And more

3. Basic Feature

Hardware Specification

ITEM		FIM3030-LV	FIM3040-LV	FIM3030-HV	FIM3040-HV
Board Spec.	CPU	ADSP-BF531			
	DRAM	8Mbyte SDRAM			
	Flash ROM	1Mbytes			
Dimension		43 x 60 [mm ²]			
Sensor		OPP03	OPP04	OPP03	OPP04
Supply Voltage		3.3 ± 0.3 [V]		5.0 ± 0.5 [V]	
Current Consumption		(Idle) 55 ~ (Op.) 210 [mA]	(Idle) 60 ~ (Op.) 200 [mA]	(Idle) 55 ~ (Op.) 210 [mA]	(Idle) 60 ~ (Op.) 200 [mA]
Operating Temperature		-20 ~ 60 [°C]			
Humidity		~ 90 [% RH]			
ESD Tolerance		B/D: ±10 [KV] (indirect) Sensor Finger contact Area: ±20 [KV] (air)			
Communication Channel		RS-232 Speed: 9600 ~ 115200 [bps]			
External I/O		3 Key Input 2 Result Output			

Operation Specification

ITEM	FIM3030-LV/HV FIM3040-LV/HV
Capture Speed	0.2(normal) / 0.7(secure) sec
Verification Speed (Normal Mode)	1.0 [sec] (Capture + Extract + Match)
Boot Up Time	Max. 0.5 [sec]
Data Encryption Method	AES for saving data

4. Block Diagram

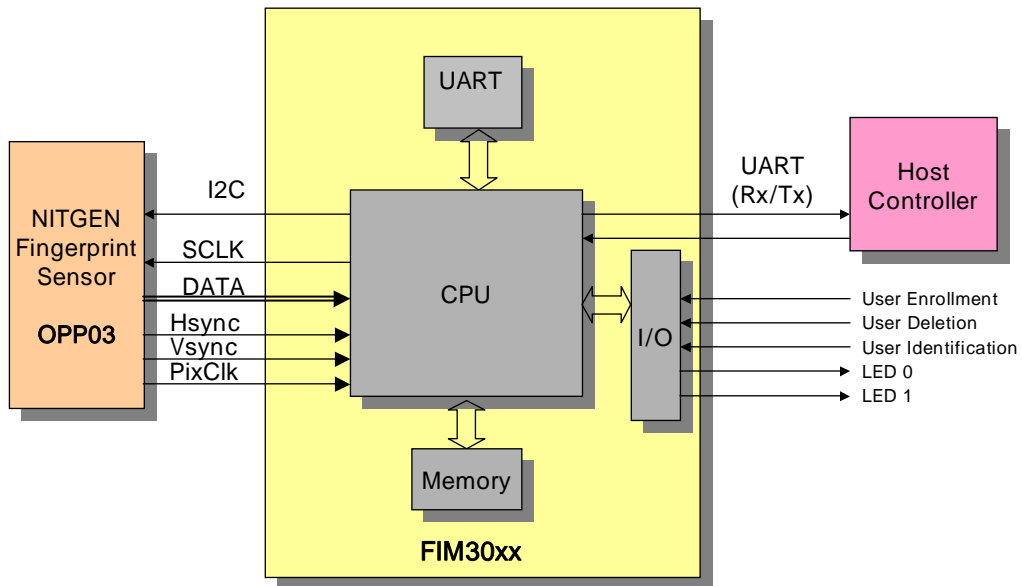

RS-232C communication data consist of 8-bit data, no parity, 1-bit start-bit and 1-bit stop-bit.

5. Operation

Communication

FIM30xx has RS-232 serial communication port through that FIM30xx communicates at the same time. These ports support 6 baudrate modes such as 9600, 14400, 19200, 38400, 57600, and 115200 bps.

FIM30xx follows NITGEN Serial Communication protocol. For more detail information refer to the document “NITGEN_ComProctocl.pdf”.

User Data Area

FIM30xx provides 64 Kbytes flash memory. Using this memory, host can save private data for specific usage. The caution is needed because the responsibility for reading, writing and erasing user data area is given to the host.

Key Function

FIM30xx supports 3 function key inputs such as Enroll_Key, Delete_Key, and Identify_Key. Using these keys without serial communication, enrollment, deletion, all deletion and identification operating can be executed.

The following timing diagram and table show the operation condition of keys.

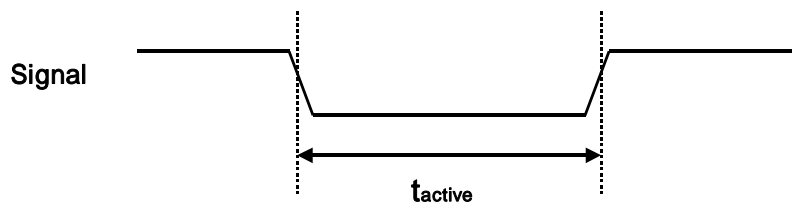

FIM30xx



Command	Signal Name	t_{active}	
		Minimum [ms]	Maximum [ms]
CMD_ENROLL	/ENROLL_KEY	30	
CMD_DELETE	/DELETE_KEY	30	3,000
CMD_IDENTIFY	/IDENTIFY_KEY	30	
CMD_DELETE_ALL	/DELETE_KEY	3,000	

FIM30xx

6. Technical Data

6.1. Physical Characteristics

The Feature of Board

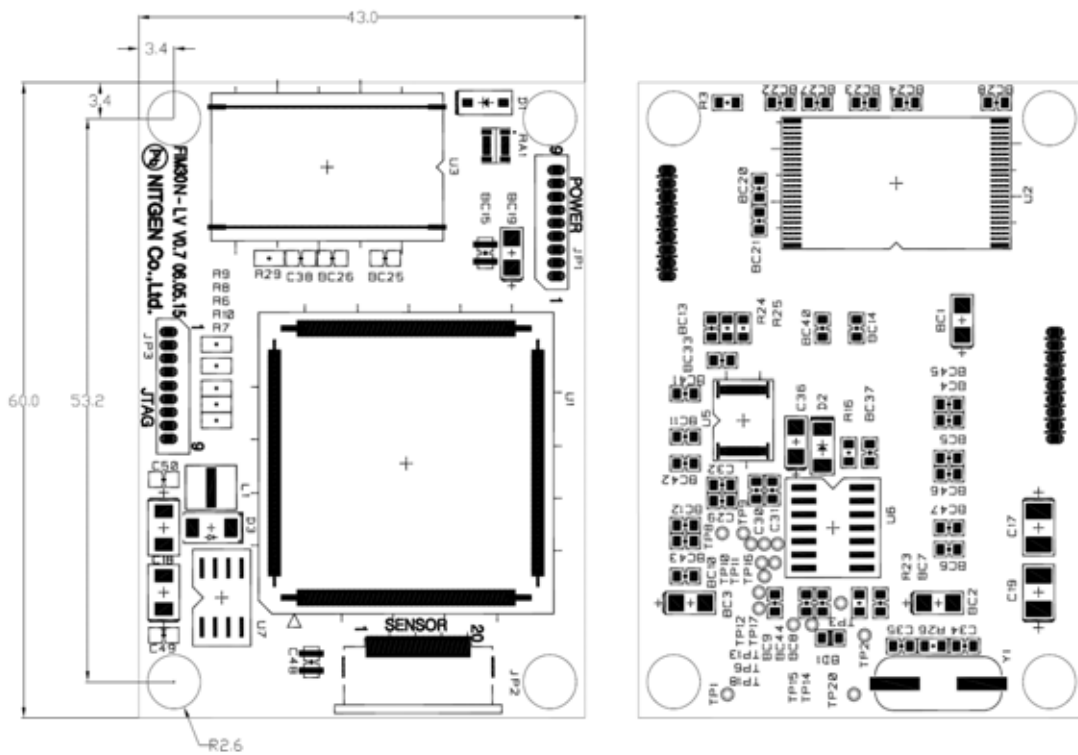

FIM3030-LV/FIM3040-LV

FIM30xx

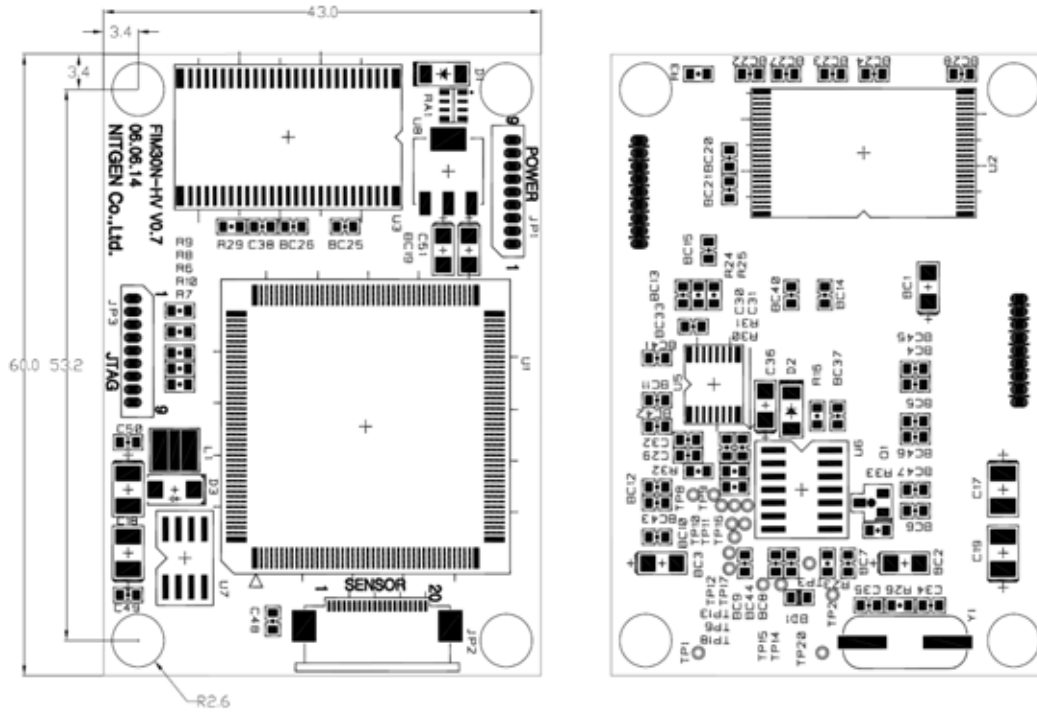

FIM3030-HV/FIM3040-HV

The feature of Optical fingerprint sensor

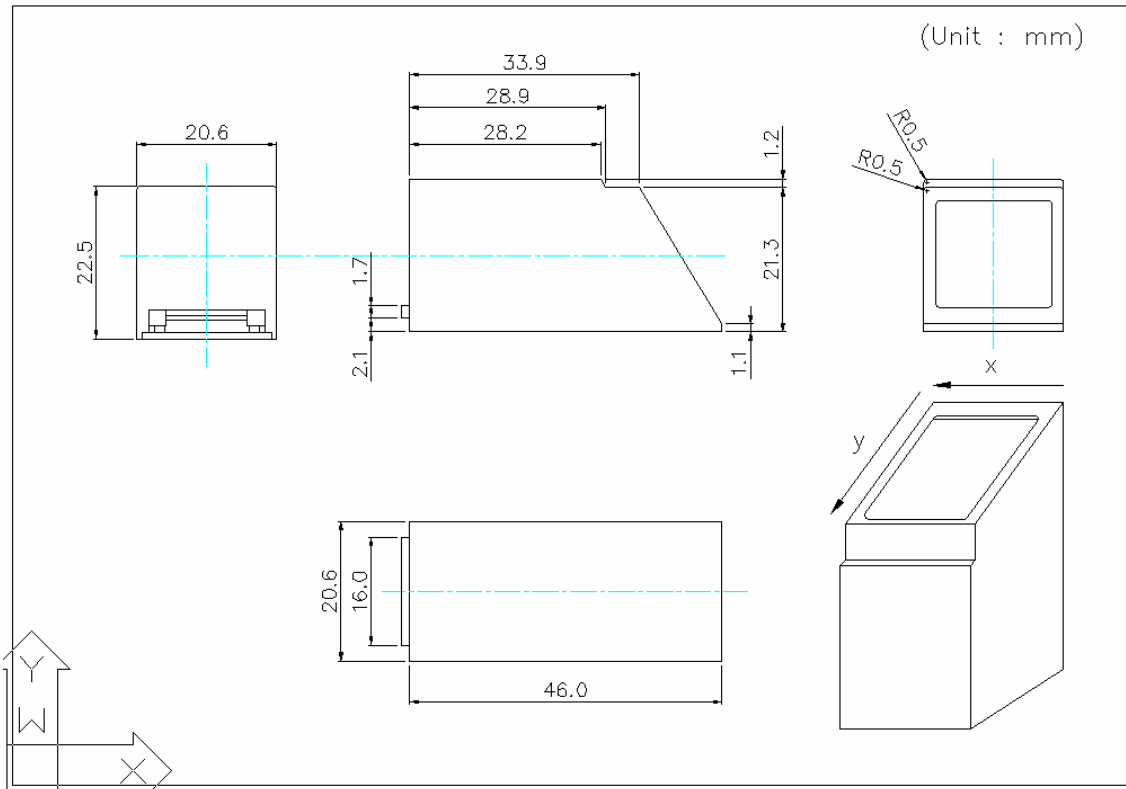

The Dimension of OPP03

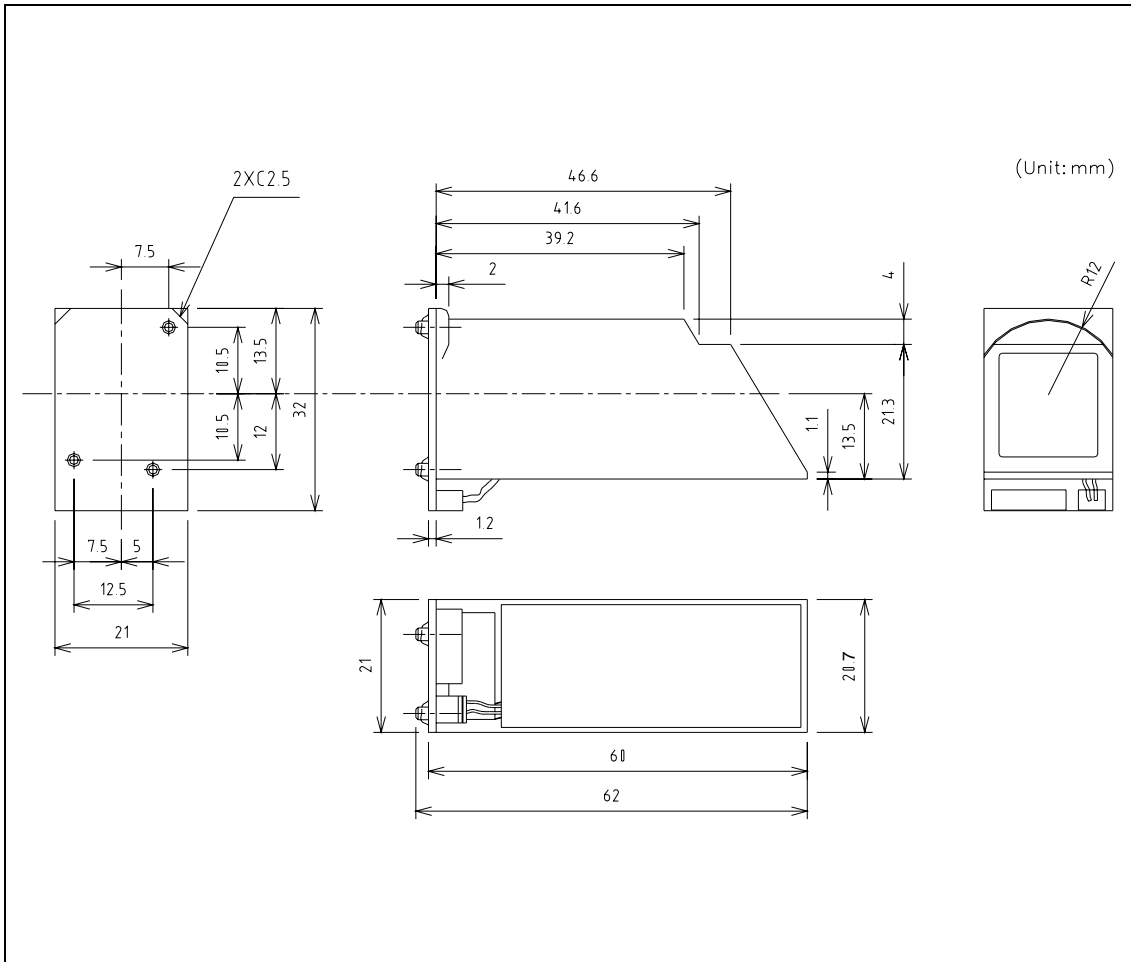

The Dimension of OPP04

6.2. External Port

- External Interface Connection (JP1)

Pin	Pin Name	Description
1	VCC	3.3 V (FIM30xx-LV) / 5 V (FIM30xx-HV)
2	RXD	RS-232 Rx receiving signal from host
3	TXD	RS-232 Tx transmitting signal to host
4	SUCCESS	Output for indicating authentication success
5	FAIL	Output for indicating authentication fail
6	Enroll_Key	Input to enroll fingerprint without RS-232 communication
7	Delete_Key	Input to delete user without RS-232 communication
8	Identify_Key	Input to identify user without RS-232 communication
9	GND	Ground

I/O Port Operation Condition (included in JP1)

Pin	Name	Direction	Initial State	Active State
4	EXT_PASS	Out	Low	High (500 ms)
5	EXT_FAIL	Out	Low	High (500 ms)
6	EXT_ENROLL	In	High	Low (more 30ms)
7	EXT_DELETE	In	High	Low (more 30ms)
8	EXT_IDENTIFY	In	High	Low (more 30ms)

- 20-Pin Sensor Connection (JP2)

Pin	Name	States	Description
1	GND	POWER	Sensor Ground
2	VCLK	IN	Sensor Clock
3	VCC	POWER	Sensor VCC (3.3V)
4			Reserved
5			Reserved
6	VSNC	IN	Vertical Sync.
7	HSNC	IN	Horizontal Sync.
8	SDATA0	IN	Sensor Data 0
9	SDATA1	IN	Sensor Data 1
10	SDATA2	IN	Sensor Data 2

11	SDATA3	IN	Sensor Data 3
12	SDATA4	IN	Sensor Data 4
13	SDATA5	IN	Sensor Data 5
14	SDATA6	IN	Sensor Data 6
15	SDATA7	IN	Sensor Data 7
16	SDA	IN/OUT	I2C Data
17	SCL	OUT	I2C Clock
18	SLED	OUT	Sensor LED
19	PIXCLK	IN	Pixel Clock
20	GND	POWER	Sensor Ground

- **JTAG (JP3)**

Pin	Pin Name	Description
1	VCC	3.3 Volt Power
2	N/A	N/A
3	nSRST	JTAG control pin
4	TDO	JTAG control pin
5	TDI	JTAG control pin
6	nTRST	JTAG control pin
7	TCK	JTAG control pin
8	TMS	JTAG control pin
9	GND	Ground

* JP1 (JTAG connector) is used only for development or emergency recovery.

6.3. Connector and Cable

6.3.1 Sensor

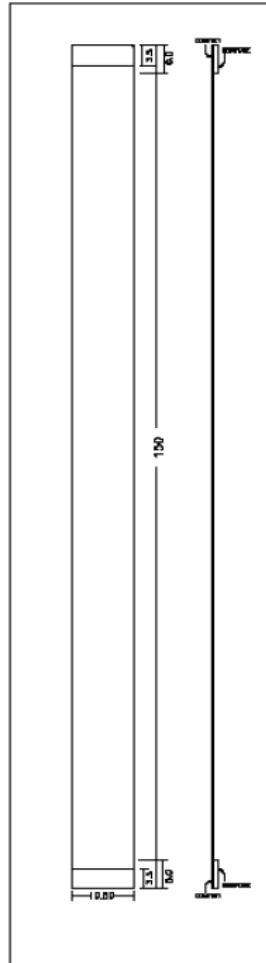

Material List

NO	DESCRIPTION	VENDOR
1	20-PIN (52746-2090)	MOLEX

6.3.2 Communication

Material List

NO	DESCRIPTION	VENDOR
1	15-PIN Male (53047-1510)	MOLEX
2	Matching Female (51021-1500)	MOLEX

6.4. Electrical Characteristics

Parameter	MIN.	TPY.	MAX.	UNITS
Power				
Supply current		210		mA
Supply Voltage (FIM30xx-LV)	3.0	3.3	3.6	V
Supply Voltage (FIM30xx-HV)	4.5	5	5.5	V
RS-232				
Output Voltage Swing	±5.0	±5.4		V
Input Voltage Range	-15		+15	V
Maximum data rate			115,200	BPS

7. Ordering Information

FIM3030 (with OPP03) Ordering Guide

Ordering Number	Supply Voltage	Max. Users
FIM3030 -LV	3.3V	100
FIM3030 -HV	5V	100
FIM3040 -LV	3.3V	100
FIM3040 -HV	5V	100

APPENDIX

Recommended circuit

Input - /ENROLL_KEY, /DELETE_KEY, and /IDENTIFY_KEY

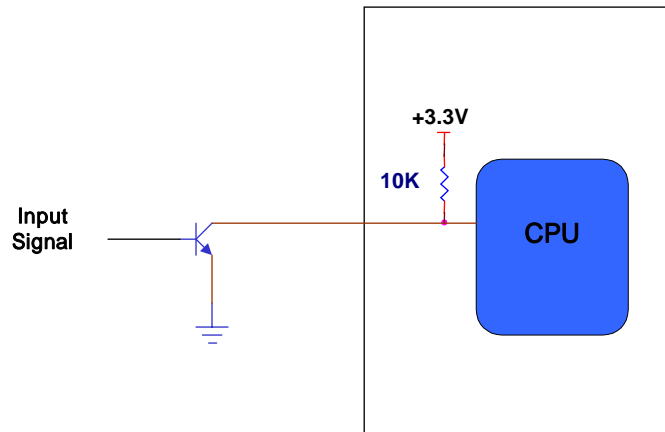

Output

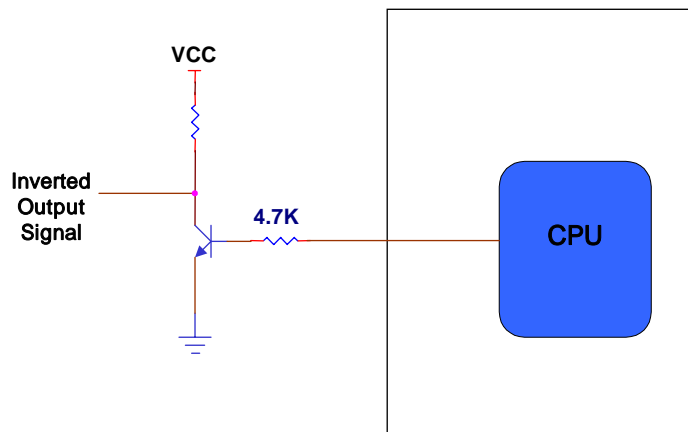

Boot up time

System Boot-up time means the total time consumed by FIM30xx after system power is supplied.

System Boot-up time can be measured as the following.

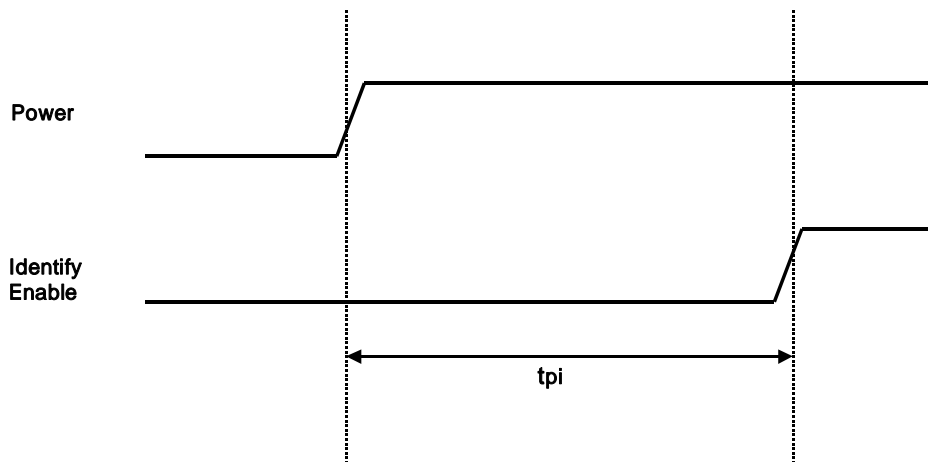

Support Information

NITGEN Co., Ltd.

Sam-O B/D 3rd FL., 905-4, Hogye-dong Dongan-gu,
Anyang City, Gyunggi-do, Korea

Tel: +82-31-451-9400

Fax: +82-31-451-6722

E-mail. Customer@nitgen.com