

HerkuleX

DRS-0602 User's Manual



Contents

1. Safety Instructions

1-1. Safe Operating Tips	03p
1-2. Safe Storage Tips	03p

2. Introduction

2-1. Parts List	05p
2-2. Product Features	05p
2-3. Specification	08p

3. Assembly Instructions

3-1. Basic Assembly	09p
3-2. Joint Assembly	11p
3-3. Connector Pin and System Configuration	16p

4. Operation

4-1. Communication Protocol	17p
4-2. Register Map	20p

5. Command Set

5-1. [To HerkuleX Servo Module] – Request Packet	36p
5-2. [To Controller(ACK)] – ACK Packet	36p
5-3. Description of CMD	37p

6. Command Examples

38p

Reference

47p

1. Safety Instructions

Thank you for purchasing our HerkuleX.

For your safety, please read the instruction manual prior to using HerkueX and make sure to follow the safety instructions below.

1-1. Safe Operating Tips



Caution Ignoring the safety instructions may lead to bodily injury to the user and to those nearby with possibility of serious injury or even death however remote.



Do not disassemble or modify Herkulex Servo.



Do not touch the HerkuleX servo casing immediately after the operation.



Keep away from sand, dust, and water.



Use the robot only in indoors.



Do not use overt force to turn the Herkulex Servo Horn,

1-2. Safe Storage Tips



Caution Ignoring the safety instructions may lead to bodily injury to the user and to those nearby with possibility of serious injury or even death however remote.



To prevent accidents and damage, do not store Herkulex Servo under the conditions listed below.

- Location with very high or low temperature
- Location with direct sunlight
- Location with high humidity
- Location with vibration
- Dusty location
- Area where electrostatic electricity may occur
- Area within easy reach of children

2. Introduction

2-1. Parts List

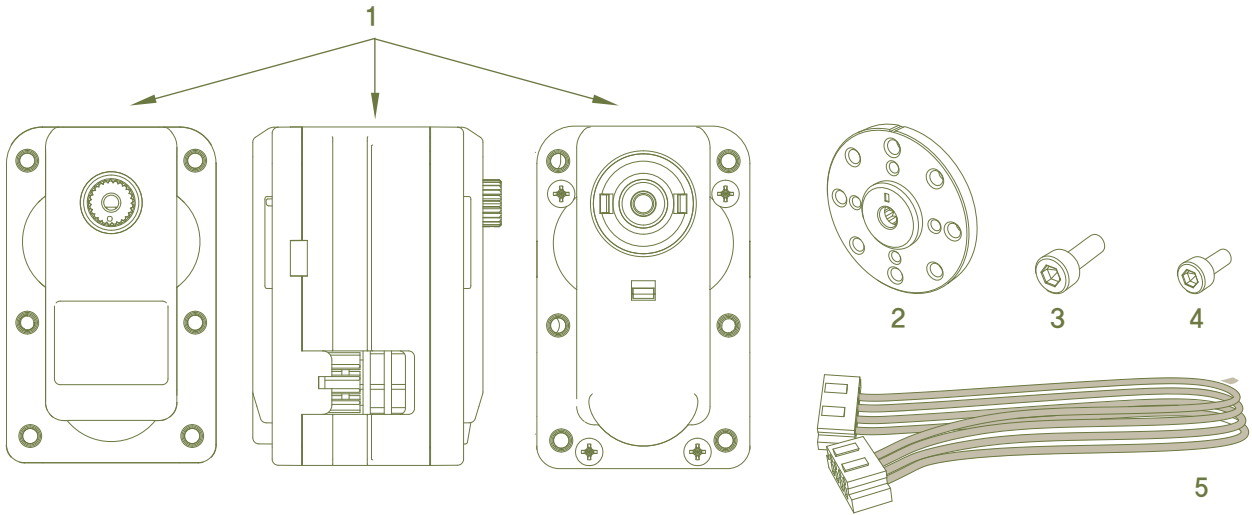

1	Herkulex Servo	: 1ea
2	Horn	: 1ea
3	Horn Bolt(M 3X6)	: 1ea
4	Bracket Assembly Bolt(M 2,6X4)	: 16ea
5	Wire Harness(200mm)	: 1ea

2-2. Product Features

Smart HerkuleX Servo

HerkuleX Servo DRS-0602 is a modular Smart HerkuleX Servo, incorporating motor, gear reducer, control circuitry, and communications capability in one single package.

DRS-0402 Smart feature is capable of detecting and responding to changes in voltage supply and internal temperature.

Simple Assembly and Wiring

Small, light, and easy to assemble. HerkuleX servos make assembling joints and wiring simple and easy task. Two connectors attached to HerkuleX servo allows serial type connection as well as parallel type connection when required.

Largest Stall Torque Relative To Size and Input Power

In relation to size, weight, and power requirement, HerkuleX has the largest stall torque in its class.

Smooth Movement

When movement command is received, HerkuleX Servo automatically creates a ladder type speed profile similar to the one shown in the diagram below to control the servo position. With the servo operating according to the acceleration/deceleration profile, vibration caused by the rapid acceleration/deceleration from the rectangular speed profile is dampened, leading to increased energy efficiency and smoother operation. Ladder type speed profile is chosen as default but profile can be change according to need to rectangular or triangular type profile.

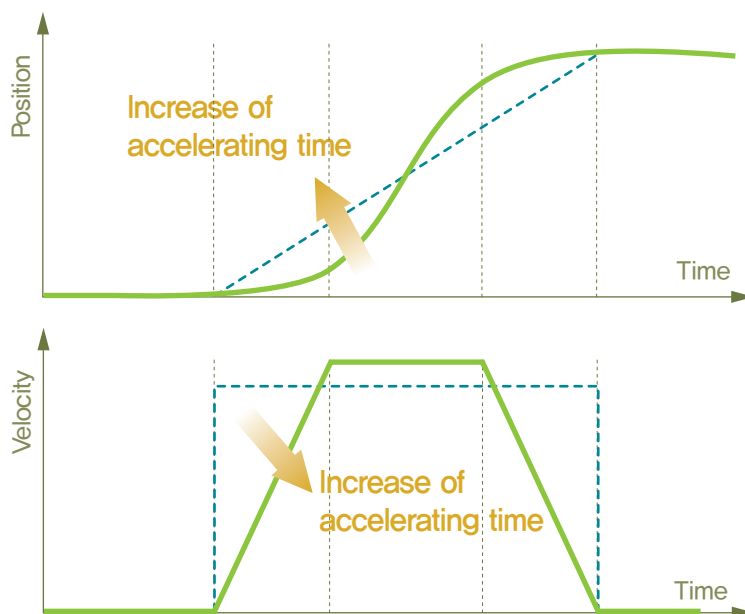

Durability

Metal Gear for high durability.

Communication

Using Multi Drop TTL Full Duplex UART Serial communication with maximum speed of 1Mbps, single command can be used to set the speed, position, LED, operational compliance, stop, and operational status of up to 254 HerkuleX servos simultaneously at once.

50 Operating Parameters

Operational parameters such as speed, calibration, elasticity, and LED could be set by writing directly to the register or by using the HerkuleX Manager downloaded from the web site with the HerkuleX Manager Kit (sold separately).

Resolution

0.02778 ° resolution provides very accurate and smooth control with minimal vibration.

Maximum Operating Angel

- Position Control Mode : 0 ~ 900 °
 - Speed Control Mode : Continuous rotation possible with rotation speed control.
- ※ When servo will be used in position control mode, servo position has to be within 0~320 ° when power is first supplied to the servo in order for initial value to be recognized. Initial position value will be 0~320 ° when power is first turned on

Compliance Control

By controlling the voltage supply according to the discrepancy between the goal position and the actual position, compliance control provides certain amount of elasticity to absorb the shock from the external force.

Data Feedback

HerkuleX Servo is capable of receiving temperature, overload, and position data feedback from the internal sensors.

Protective Features

- Internal temperature sensor monitors the internal temperature and issues Exceed Temperature limit Error if the HerkuleX Servo or circuit temperature exceeds the set value.
- Overload detected Error is issued when the load stress on HerkuleX Servo exceeds the set value. These safety features protect HerkuleX from potential damage and prolongs the servo life.

Self-Test

HerkuleX self-test feature is capable of detecting 6 different types of error which are then indicated by the blinking LED. HerkuleX Manager is used to set the error conditions, response policy, and etc.

Multi Drop Network

Multil Drop Network with 1:n Controller to HerkuleX servo ratio.

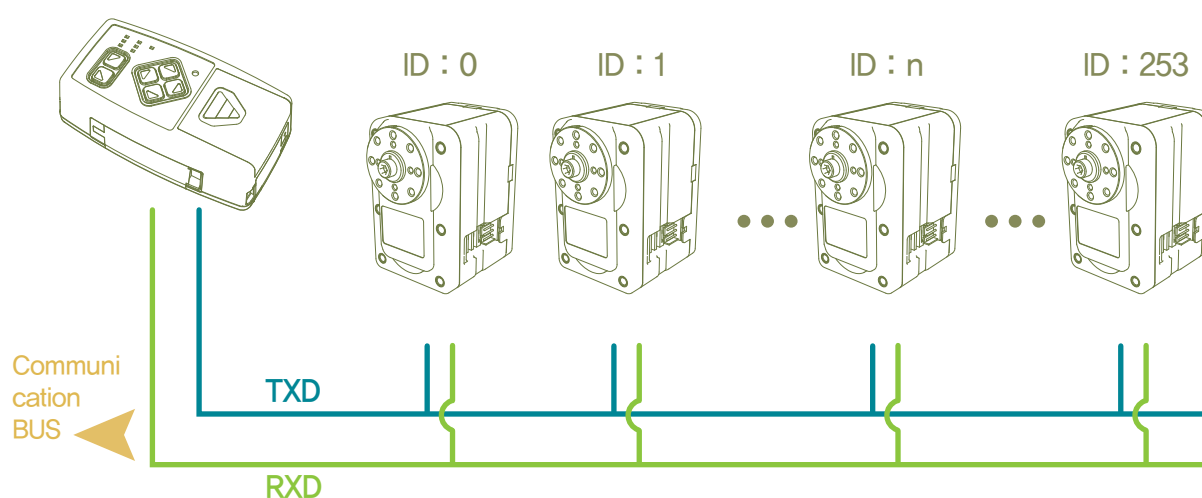

Multi Function LED

User has direct control over the three installed LEDs Red/Green/Blue which are used for decorative and self-test purposes. Each LED can be controlled independently and LED commands can be sent together with the operating commands.

※ In case of error, self-test function ignores all LED commands and blinks the red LED according to the setting.

Metal Ball Bearing

Metal Ball Bearing installed in the wheel gear or on the last gear shaft will prevent the shaft from bending or gear going out of mesh due to external force.

2-3. Specification

Dimension / Weight	56mm(W) x 35.0mm(D) x 46mm(H) / 145g
Reduction Ratio Gear Material	1 : 202 Super Reinforced Metal
Input Voltage Standby Current Motor	9.5~14.8VDC(Optimized 12.0V) 33mA @ 14.8V Premium FAULHABER Coreless DC W/Integrated Magnetic Encoder
Stall Torque	7.6N.m @ 14.8V
Maximum Speed	0.164s/60 ° @ 14.8V
Resolution	Approximately 0.02778 ° (12962 Steps)
Operating Angle Temperature	900 ° , Continuous Rotation (Velocity Control) 0 ~ 80°C [32°F~176°F]
Communication Link ID, Maximum Baud Rate	Full Duplex Asynchronous Serial(TTL Level), Binary Packet, Multi Drop 0 ~ 253, 254(Broadcast only) Maximum 1Mbps
Feedback	5 Position, Speed, Temperature, Load, Voltage, Real Time Tick, etc.
Control Algorithm	PID, Feedforward, Trapezoidal Velocity Profile, Velocity Override, Velocity Control Torque Saturator & Offset, Overload Protection, Neutral Calibration, Dead Zone 54 Selectable Setting Parameters(※ HerkuleX Manager Kit Required)

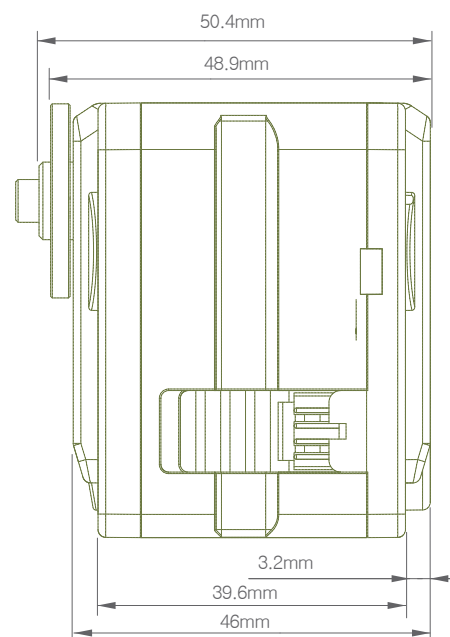
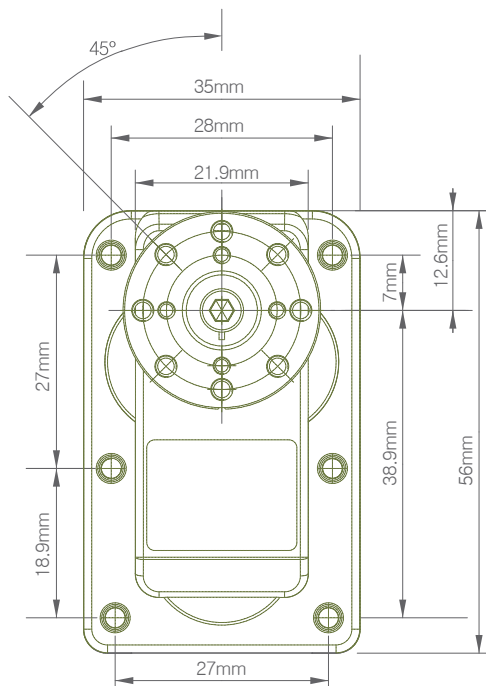

3. Assembly Instructions

3-1. Basic Assembly (Brackets and bolts sold separately)

Idle Horn

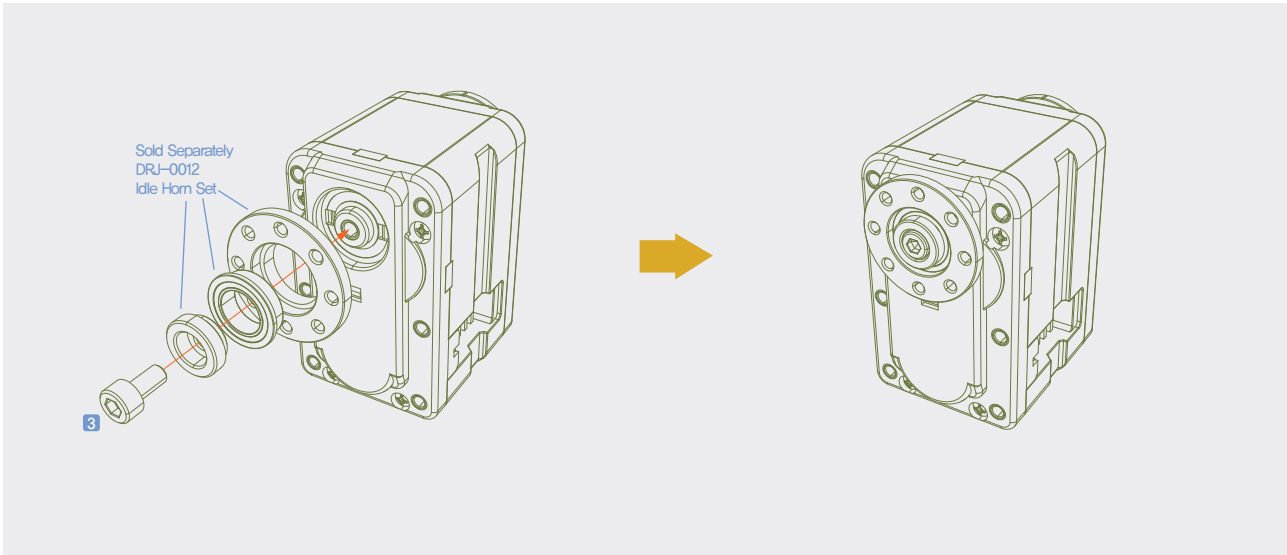

Assembly Method

Assembled Unit

L Mount

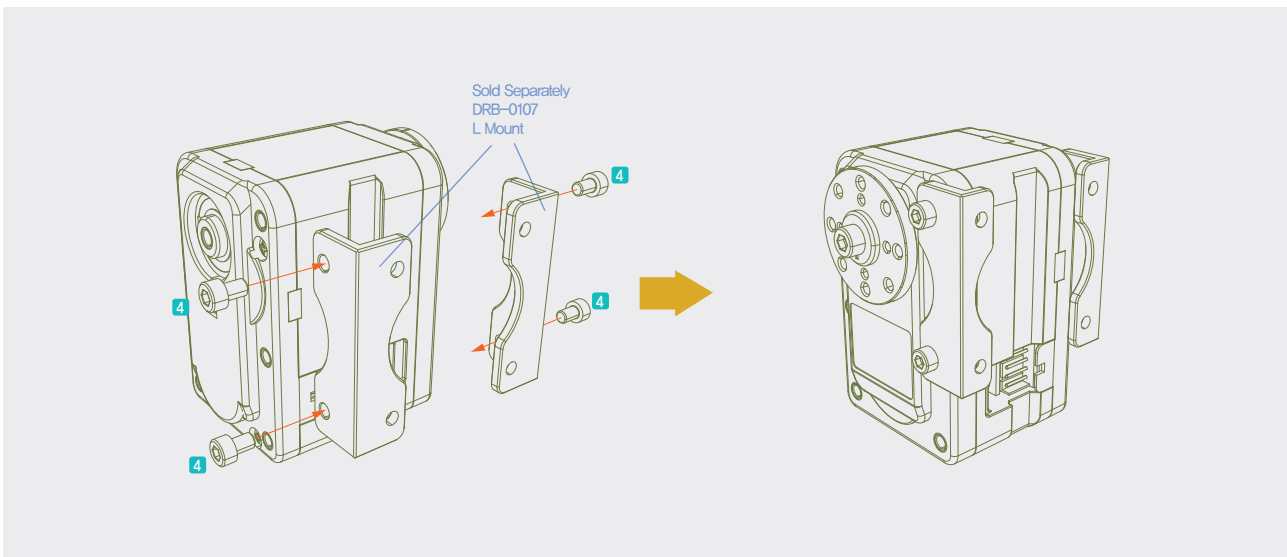

Assembly Method

Assembled Unit

Rear Mount

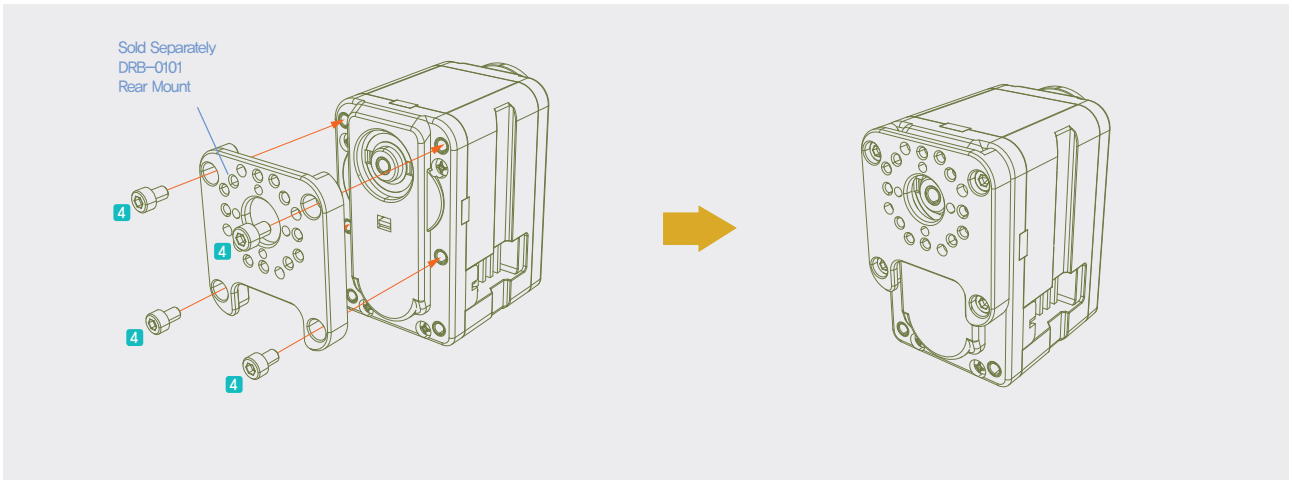

Assembly Method

Assembled Unit

Side Mount 1

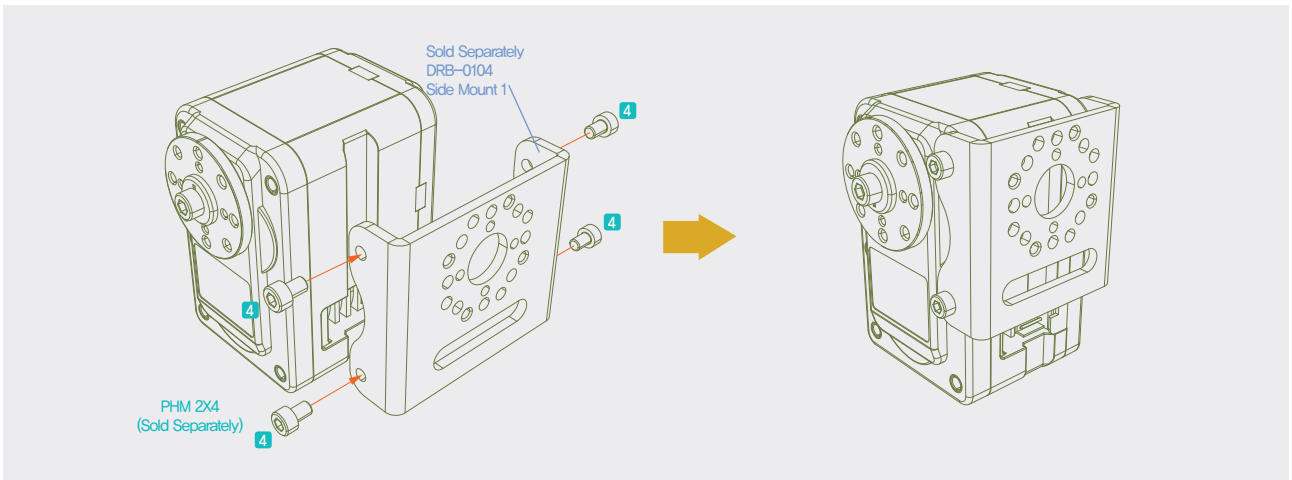

Assembly Method

Assembled Unit

Side Mount 2

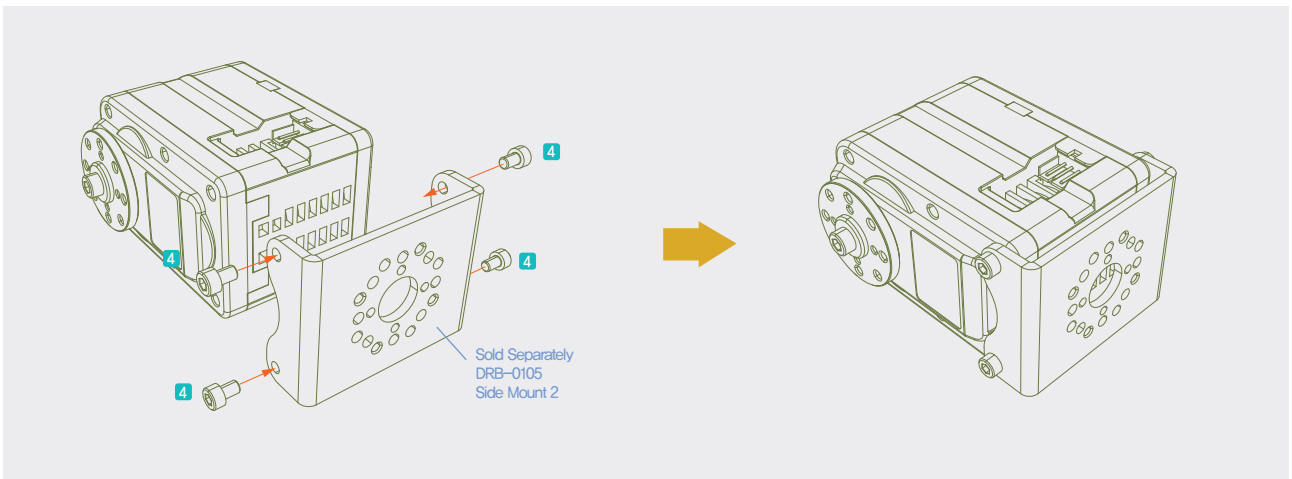

Assembly Method

Assembled Unit

3-2. Joint Assembly (Brackets and bolts sold Separately)

Arm Mount

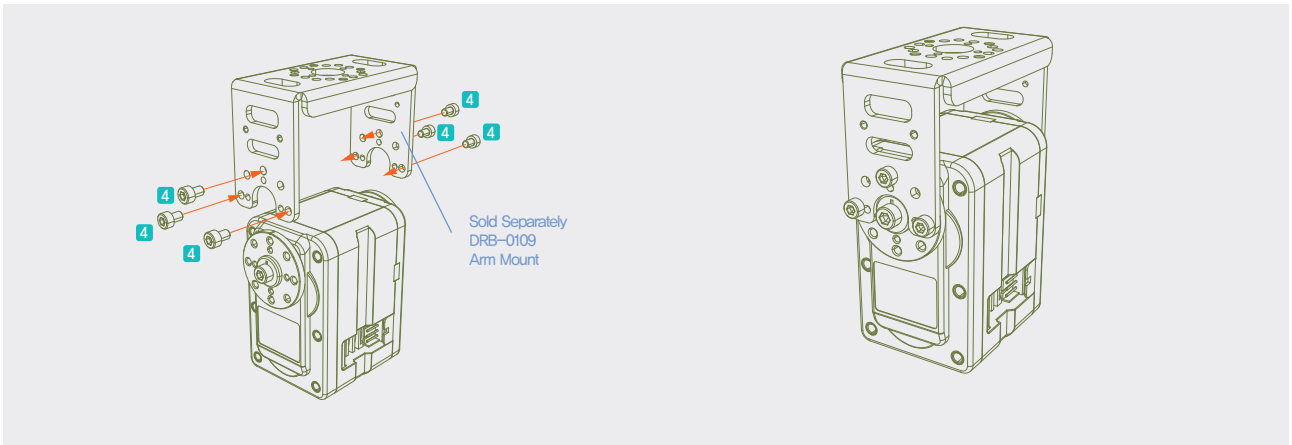

Assembly Method

Assembled Unit

Hip Joint Assembly (L Mount + Side Mount 1)

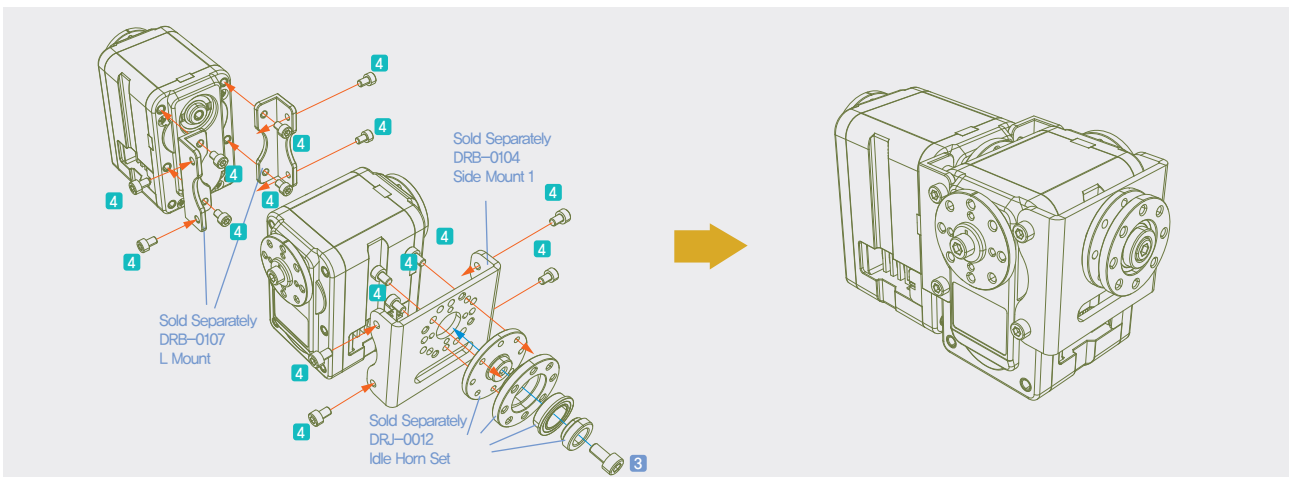

Assembly Method

Assembled Unit

Side Mount 1 + Side Mount 2 Assembly

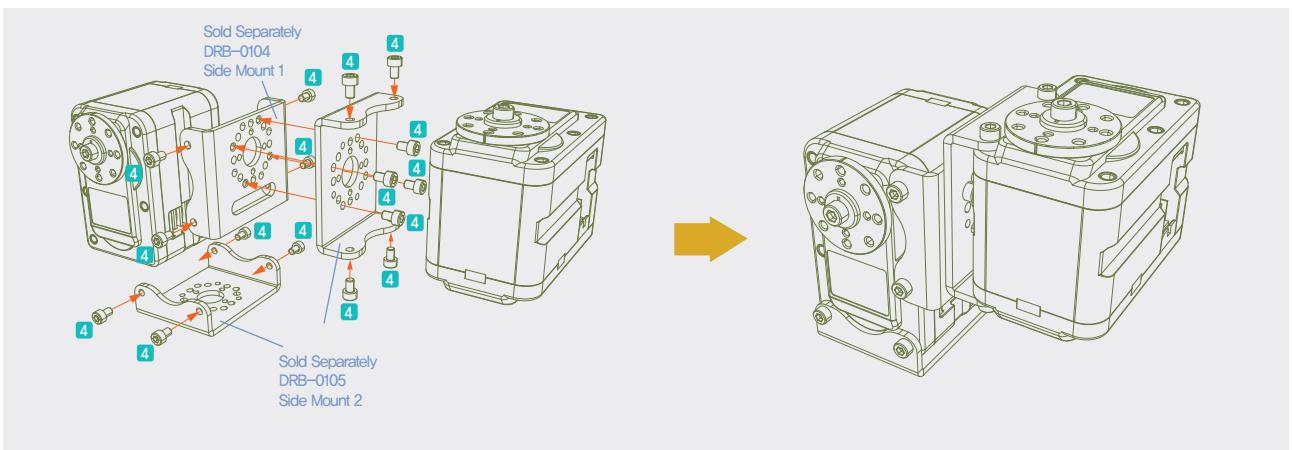

Assembly Method

Assembled Unit

Side Mount 1 + Side Mount 2 Assembly

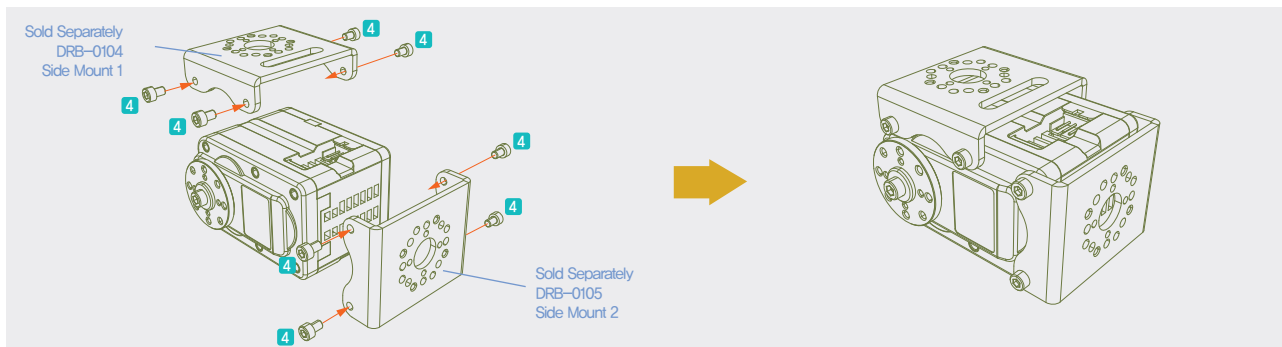

Assembly Method

Assembled Unit

Arm Assembly (Side Mount 1 + Arm Mount)

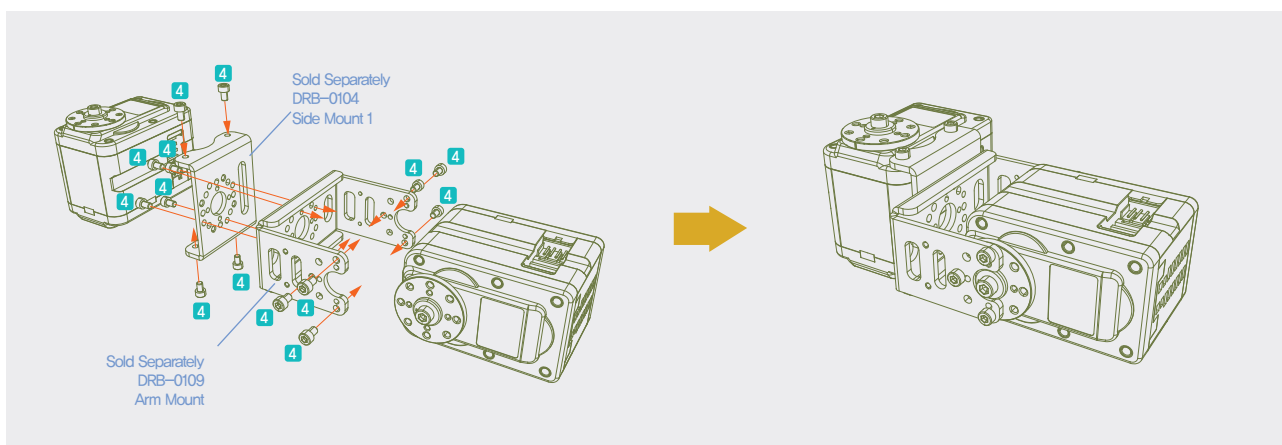

Assembly Method

Assembled Unit

3-3. Connector Pin and System Configuration

All HerkuleX Servo to HerkuleX Servo connectors have the same pin map as shown in the diagram below. Multi Drop Network makes expansion easy.

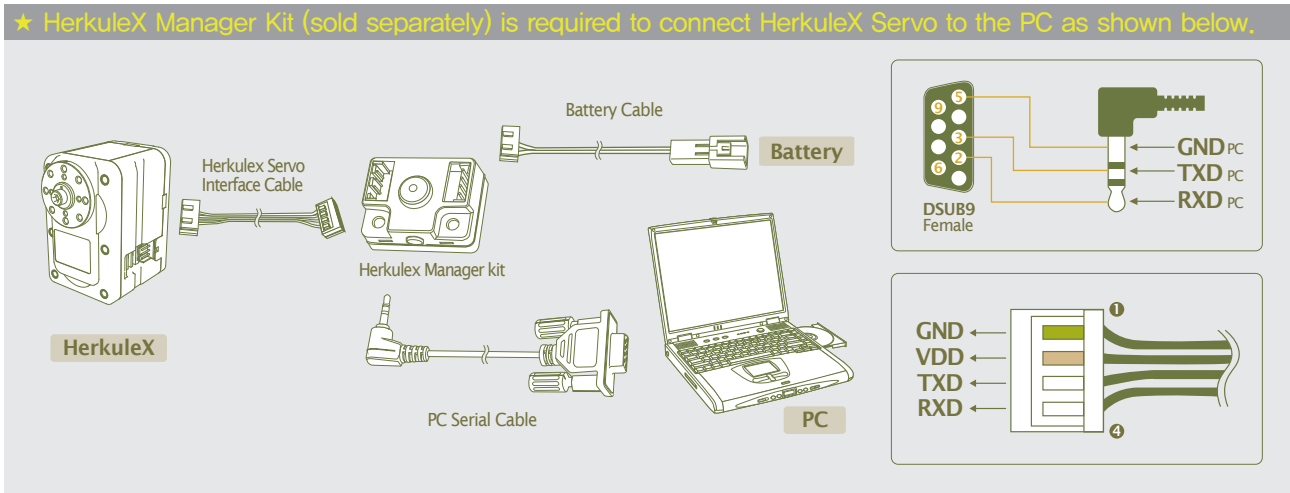
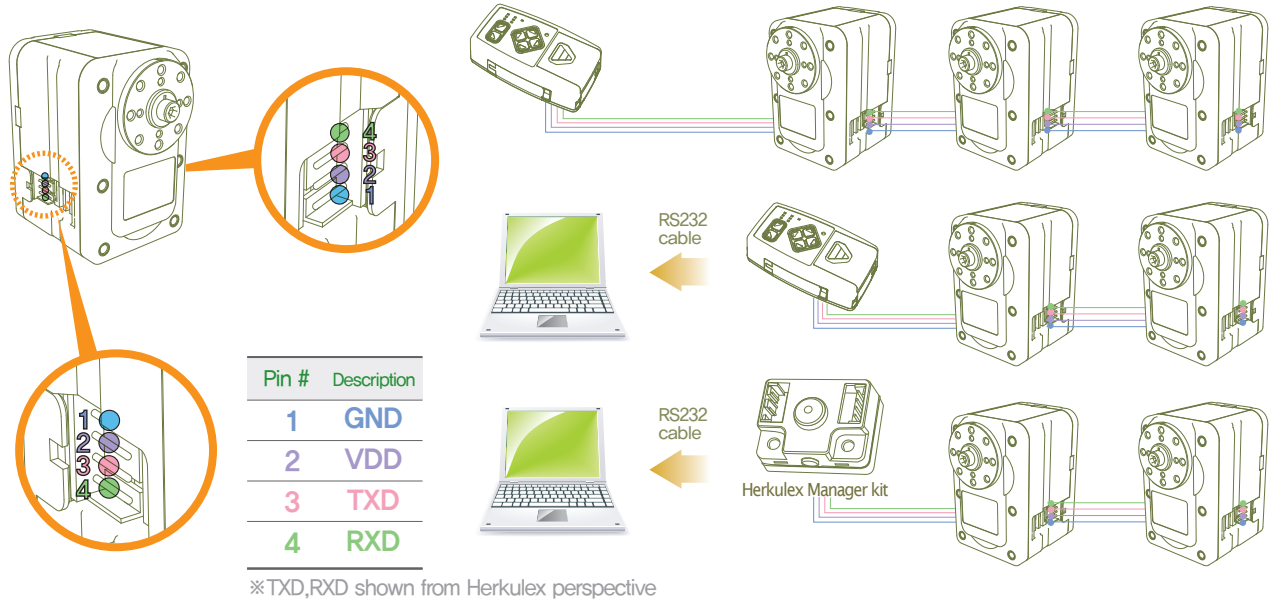

! Caution

HerkuleX Servo has to be Cross connected to the PC or controller. For example, HerkuleX Servo TXD would connect to PC or controller RXD and HerkuleX Servo RXD would connect to PC or controller TXD.

! Caution

Do not connect HerkuleX Servo directly to the PC without using the controller or HerkuleX Manager Kit. Even though communication signal (RXD/TXD) between the PC and the controller or HerkuleX Manager Kit has the same serial communication protocol (RXD/TXD) as the communication between the HerkuleX Servos, they are not directly compatible due to difference in electrical property.

! Caution

Make sure to check the Connector Pin assignment when using custom made wire harness. HerkuleX Servo LED will blink once if it is receiving power properly. If LED does not blink, check the connector pin assignment, power supply voltage and Amp to make sure everything is proper order.

4. Operation

4-1. Communication Protocol

Introduction

Servo Controller communicates with the servos in the network by sending a Request Packet and receiving ACK Packet back from the servo. The example below shows the controller sending a Request Packet to the Servo ID (n) and receiving ACK packet back from the Servo ID (n). Regardless of the number of servos connected in the Multi Drop network, only the servo with correct ID (n) will acknowledge the Request Packet.

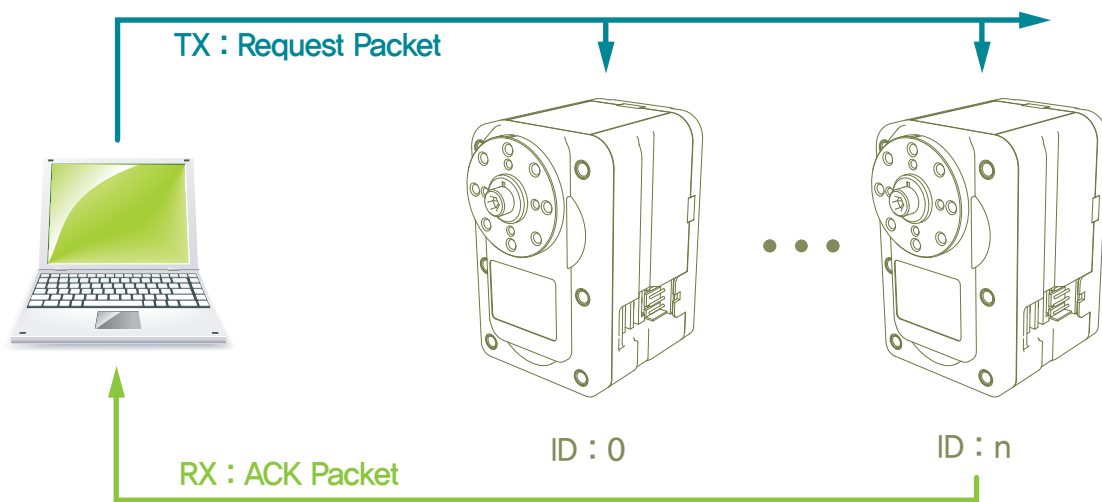

Herkulex Servo Communication Setup

Data Bit : 8
 Stop Bit : 1
 Parity : None
 Flow Control : None
 Baud Rate : 57,600 / 115,200 / 0.2M / 0.25M / 0.4M / 0.5M / 0.666,666M / 1Mbaud

※ The communications speed of the PC communication ports or USB to Serial Cable can be limited by the hardware or by the device driver. If problem occurs, check the Baud Rate of the involved port of peripheral to make sure 115,200bps is supported. If the supported Baud Rate can not found, set the Baud Rate to 115,200bps or 57,600bps and try again. The default factory setting for DRS-0602 is 115,200bps.

Packet

Type	Header		Packet Size	pID	CMD	Check Sum1	Check Sum2	Data[n]
Value	0xFF	0xFF	7~223	0~0xFE	1~9	Ref to details	Ref to details	Ref to details
Byte	1	1	1	1	1	1	1	MAX 216

► Header

Indicates start of the Packet.

Type	Header	
Value	0xFF	0xFF
Byte	1	1

► Packet Size

Refers to total Packet size (in Bytes) from Header to Data. The maximum Packet Size 233, if the packet size is larger than 223 Bytes, packet may not be recognized. Minimum packet size without any data is 7.

► pID

Unique pID value can range from 0 ~ 253 which is total number of servos in the network. Care must be taken when using pID value of "0xFE" which is a special value that affects all the servos in the network.

※ To avoid confusion with Servo ID, ID within the packet is denoted pID

Type	pID
Value	0 ~ 0xFE
Byte	1

► CMD

CMD refers to the actual command for HerkuleX servo to perform when packet is received. There are 9 types of CMD in Request Packet EEP_WRITE(0x01), EEP_READ(0x02), RAM_WRITE(0x03), RAM_READ(0x04), I_JOG(0x05), S_JOG(0x06), STAT(0x07), ROLLBACK(0x08), REBOOT(0x09). ACK Packet also has equivalent set of CMDs, but to distinguish from the Request CMD, 0x40 OR operation (+) is performed to the ACK Packet. For example, ACK Packet CMD for Request packet EEP_WRITE(0x01) would be 0x41.

Type	CMD
Value	0x01 ~ 0x09 : Request Packet 0x41 ~ 0x49 : ACK Packet
Byte	1

※Refer to Page 36 for detailed information concerning CMD,

► Check Sum1

Check Sum1 is used to check for errors in the Packet. Check Sum1 is calculated as follows,
 $\text{Check Sum1} = (\text{PacketSize} \wedge \text{pID} \wedge \text{CMD} \wedge \text{Data}[0] \wedge \text{Data}[1] \wedge \dots \wedge \text{Data}[n]) \& 0\text{xFE}$.
Header, Check Sum1, Check Sum2 are not included in the calculation.

※ ‘A ^ B’ : Bit Exclusive OR Operator, A is different from B 1(True), same 0(False)

Type	Check Sum1
Value	$(\text{PacketSize} \wedge \text{pID} \wedge \text{CMD} \wedge \text{Data}[0] \wedge \text{Data}[1] \wedge \dots \wedge \text{Data}[n])\&0\text{xFE}$
Byte	1

► Check Sum2

Checksum2 is also used to check for errors in the Packet. Check sum2 is calculated as follows,
 $\text{Check sum2} = (\sim(\text{PacketSize} \wedge \text{pID} \wedge \text{CMD} \wedge \text{Data}[0] \wedge \text{Data}[1] \wedge \dots \wedge \text{Data}[n]))\&0\text{xFE}$

※ ‘~ A’ : Bit Not Operator, A = 0 1(True), A = 1 0(False)

Type	Check Sum2
Value	$(\sim(\text{PacketSize} \wedge \text{pID} \wedge \text{CMD} \wedge \text{Data}[0] \wedge \text{Data}[1] \wedge \dots \wedge \text{Data}[n]))\&0\text{xFE}$
Byte	1

► Data[n]

Number of Data depends on CMD and some CMD may not have Data field. Refer to CMD for details.

Type	Data
Value	Refer to CMD for details
Byte	Max216

4-2. Register Map

Register Map are values residing within the Servo and contain data pertaining to current servo status and operation. Registers are either Non-Volatile or Volatile. Users are able to control the servos by using Request Packet and ACK Packet to either check or change the data in the Register Map.

Non-Volatile Register(EEP Register) Map

Non-Volatile memory retains data without power. Once the power is turned on, data in the Non-Volatile memory in EEPROM Register are copied to the RAM Register which is Volatile memory. Data in the Non-Volatile memory does not have direct affect on HerkuleX servo operation once it has been copied to the RAM Register. Rebooting the HerkuleX servo will again copy the data from EEPROM Register to the RAM Register.

► Address

Address refers to the address of the Register. To Read/Write to the Register, Register address must be included in the Packet.

► Default

Factory Default Value, Rollback Protocol is used to return all values to Factory Default Value.

► Valid Range

Range of valid data values HerkuleX servo can have. HerkuleX servo may exhibit erratic or unpredictable behavior if the data entered is outside of the Valid Range.

► RO(Read Only), RW(Read Write)

RO refers to read only Registers. Writing to RO Register will result in error.

RO Registers hold fixed HerkuleX servo values (Model #, Version) or sensor values used for feedback.

RW refers to Registers which be both read and written to.

※ e (Reg_Name) : Refers to Reg_Name in EEPROM Register.

※ r (Reg_Name) : Refers to Reg_Name in RAM Register.

► Max. PWM, Dead Zone

- PWM is a value representing voltage (Energy) entering HerkuleX Servo. Greater the input voltage the greater the torque or speed.
 - Max. PWM : Limits maximum PWM, in other words, maximum allowed input voltage. Energy use is optimized by limiting the maximum torque or speed of HerkuleX Servo.
 - Dead Zone : 0 and the servo stops. HerkuleX Servo moves to reach the exact Goal Position. When the difference (Error) between the current position and the goal position becomes 0, force drops to 0 and servo stops. Dead Zone provides flexibility to the servo operation by increasing the range where force drops to 0. If the difference (Error) is less than the Dead Zone, servo assumes it has reached the goal position and stops.
- ※ What does “operational flexibility” refer to?
In the graph below, green line is the PWM level without Max. PWM and Dead Zone set. Red line is with PWM and Dead Zone set. Red line shows PWM dropping to 0 within the Dead Zone even though Goal Position has not been reached. On the right side of the graph, even though green line is above (larger) than the Max. PWM, actual PWM value (red line) remains at Max. PWM.
- ※ Setting large Dead Zone will increase the discontinuous PWM range which decreases controllability. Recommended Dead Zone value is below 10.

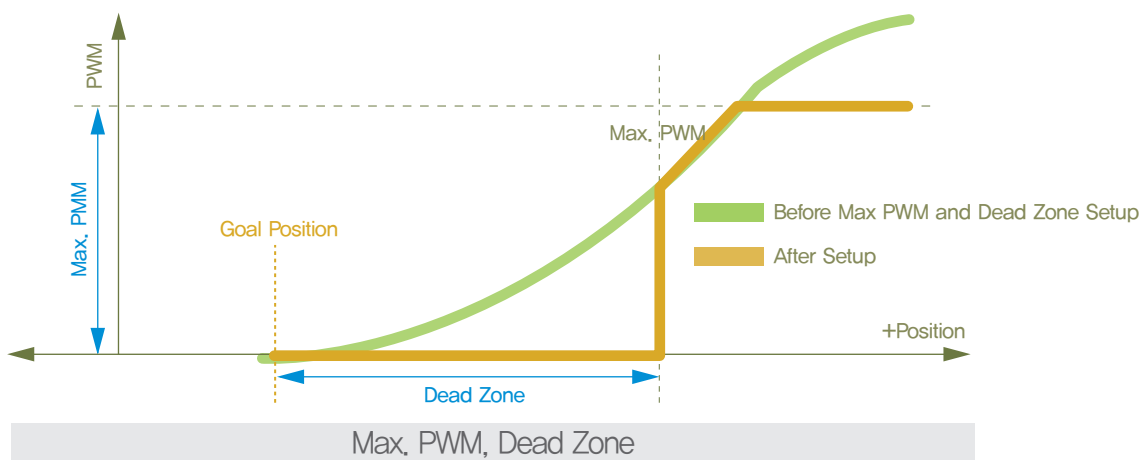

Volatile Register(RAM Register) MAP

Volatile Memory has direct affect on the operation of the Servo and reverts to default (EEP Register) value when the Servo is reboot even though RAM register value has been changed to change the servo operating parameters. Read/Write has to be performed to RAM Register value to operate the Servo, change the operating parameters or to check servo status.

Register Details

NO	Type	Bytes	EEP(ROM) ADDR	RAM ADDR	Default (DRS-0602)	Valid Range	RW	Description/Meaning
1	Model No1	1	0	—	0x04	—	RO	Upper 2 digits of model number, Ex) DRS-0602 : No1(0x06)
2	Model No2	1	1	—	0x02	—	RO	Lower 2 digits of model number
3	Version1	1	2	—	0x00	—	RO	Firmware Version
4	Version2	1	3	—	0x90	—		
5	Baud Rate	1	4	—	0x10	0x01~0x04, 0x07, 0x09, 0x10, 0x22	RW	<p>Communication speed between Servo and controller Default Baud Rate is 115,200bps</p> <ul style="list-style-type: none"> • 0x01 : 1,000,000 bps • 0x02 : 666,666 bps • 0x03 : 500,000 bps • 0x04 : 400,000 bps • 0x07 : 250,000 bps • 0x09 : 200,000 bps • 0x10 : 115,200 bps • 0x22 : 57,600 bps <p>※ Baud Rate margin of error set at less than 3%</p>
6	Reserved	1	5	—	—	—	—	Reserved
7	ID	1	6	0	0xDB	0x00~0xFD	RW	<ul style="list-style-type: none"> • Herkulex Servo ID, Error when same ID exists within the network, ID range 0 ~ 253 , Default(0xDB,219) • ※ pID up to 254, Herkulex Servo max ID is 253
8	ACK Policy	1	7	1	0x01	0x00~0x2	RW	<p>Set ACK packet reply policy when Request Packet received.</p> <p>0 : No reply</p> <ul style="list-style-type: none"> • 1 : Only reply to Read CMD • 2 : Reply to all Request Packets • ※ When CMD is STAT, ACK packe will be sent regardless of r(ACK Policy) • ※ When pID(Broadcast pID)is 254 no reply (Exception when CMD is STAT)
9	Alarm LED Policy	1	8	2	0x5F	0x00~0x7F	RW	<ul style="list-style-type: none"> • Alarm LED blink policy, Blinke LED when r(Alarm LED Policy) & r(Status Error) is true • LED blink period set by r(LED Blink Period), ignore r(LED Control) value when LED blinking • r(LED Control) operate normally only en r(Status Error) deactivated. • ※DRS-0602 : 0x20(Driver fault) not supporte, always 0
10	Torque Policy	1	9	3	0x15	0x00~0x7F	RW	<ul style="list-style-type: none"> • r(Servo Policy) & r(Status Error) TRUE) Torque release(Torque Off) • When Torque released, by errorTorque On not possible regardless of value in r(Torque Control) • Servo does not automatically revert to Torque On even after r(Status Error) has been resolved • Enable Toque On using r(Torque Control) after r(Status Error) has been resolved • ※DRS-0602 : 0x20(Driver fault) not supported, always 0.
11	Reserved	1	10	4	—	—	—	Reserved
12	Max. Temperature	1	11	5	80	0~110	RW	<ul style="list-style-type: none"> • Herkulex Servo maximum operating temperature (celcius expressed by decimal number) • When r(Temperature) is greater than r(Max Temperature) r(Status Error) "Exceed Temperature Limit" set. • ※DRS-0602(Actual physical value shown / 1= 1°C)
13	Min. Voltage	1	12	6	95	92~200	RW	<p>Minimum Servo operating voltage</p> <ul style="list-style-type: none"> • When Herkulex Servo input voltage r(Voltage) is less than r(Min Voltage), r(Status Error) "Exceed Voltage Limit" set. • Voltage value x 10 expressed by decimal number (1= 0.1V)
14	Max. Voltage	1	13	7	170	92~200	RW	<p>Maximum Servo operating voltage</p> <ul style="list-style-type: none"> • When Herkulex Servo input voltage r(Voltage) is larger than r(Max Voltage), r(Status Error) "Exceed Voltage Limit" set. • Voltage value x 10 expressed by decimal number (1= 0.1V)

NO	Type	Bytes	EEP(ROM) ADDR	RAM ADDR	Default (DRS-0602)	Valid Range	RW	Description/Meaning
15	Acceleration Ratio	1	14	8	25	0x00~50	RW	Speed profile acceleration ratio. <ul style="list-style-type: none"> • Ratio (%) of Motion command (L_JOG, S_JOG) operating time. • Acceleration ratio is same as deceleration ratio Maximum r(Acceleration Ratio) value is 50 • Ex) When operating time is 100ms and r(Acceleration Ratio) is 20 : Acceleration time is $100 \times 0.2 = 20\text{ms}$ <ul style="list-style-type: none"> * When r(Acceleration Ratio) is 0, speed profile is rectangle * When r(Acceleration Ratio) is below 50 velocity profile is triangle
16	Max. Acceleration Time	1	15	9	0x2D	0x00~0xFE	RW	Maximum acceleration time(1 : 11.2ms) <ul style="list-style-type: none"> • When maximum acceleration time r(Max. Acceleration Time) is 254 = 2.844sec <ul style="list-style-type: none"> * When r(Max. Acceleration Time) is 0 velocity profile is rectangle
17	Dead Zone	1	16	10	0x00	0x00~0xFE	RW	Dead Zone Dead Zone only functions with position control
18	Saturator Offset	1	17	11	0x00	0x00~0xFE	RW	Set Saturator curve Offset * Not applicable during Infinite Turn
19	Saturator Slope	2	18	12	0x0000	0x0000~0x7FFF	RW	Set Saturator slope <ul style="list-style-type: none"> • Saturator Disable when '0' • Relationship between Saturator slope and r(Saturator Slop). Saturator slope= r(Saturator Slop) / 256 <ul style="list-style-type: none"> * Not applicable during Infinite Turn
20	PWM Offset	1	20	14	0x00	-128~127	RW	<ul style="list-style-type: none"> • PWM Offset value PWM increases by r(PWM Offset) amount <ul style="list-style-type: none"> * When PWM is at maximum value, HerkuleX Servo at current load outputs maximum Torque and speed * When PWM is 0, Servo stopped * Maximum PWM value 1023 * Not applicable during infinite Turn
21	Min. PWM	1	21	15	0x00	0~254	RW	Minimum PWM = Minimum Torque limit * When PWM is at minimum, HerkuleX Servo at current load outputs minimum torque and speed
22	Max. PWM	2	22	16	0x3FF	0x0000~0x03FF	RW	Maximum PWM = Maximum Torque limit <ul style="list-style-type: none"> * Smaller the maximum PWM value, smaller the maximum torque. * When PWM is at maximum value, HerkuleX Servo outputs maximum torque and speed at current load.
23	Overload PWM Threshold	2	24	18	0x03FE	0x0000~0x03FF	RW	PWM threshold for Overload decision <ul style="list-style-type: none"> • External force is divided into 0~1023 steps. Overload decision is made when when force larger than r(Overload PWM Threshold) is exerted for period longer than r(Overload Detection Period). • Overload will not occur if original value is >1023
24	Min. Position	2	26	20	10627	0~32767	RW	Minimum operating position When requested position is lower than r(Min. Position), "Exceeded Allowed Position Limit" error is registered in r(Status Error) and actual operation is limited to r(Min. Position)
25	Max. Position	2	28	22	22129	0~32767	RW	Maximum operating position When requested position is greater than r(Max. Position), "Exceeded Allowed Position Limit" Error is registered in r(Status Error) and actual operation is limited to r(Max. Position).

NO	Type	Bytes	EEP(ROM) ADDR	RAM ADDR	Default (DRS-0602)	Valid Range	RW	Description/Meaning
26	Position Kp	2	30	24	0x0046	0x0000~0x7FFF	RW	Position controller P Gain, input value is 8x amplified value, use controller after dividing by 8. Actual P Gain=(Position Kp)/8
27	Position Kd	2	32	26	0x0000	0x0000~0x7FFF	RW	Position controller D Gain, input value is 8x amplified value use controller after dividing by 8. Actual D Gain=(Position Kd)/8
28	Position Ki	2	34	28	0x0000	0x0000~0x7FFF	RW	Position controller I Gain, Input value is 16384x amplified value use controller after dividing by 16384. Actual I Gain=(Position Ki)/16384
29	Position Feedforward 1st Gain	2	36	30	0x0000	0x0000~0x7FFF	RW	Position feedforward 1st Gain
30	Position Feedforward 2nd Gain	2	38	32	0x0000	0x0000~0x7FFF	RW	Position feedforward 2nd Gain
31	Velocity Kp	2	40	34	0x0064	0x0000~0x7FFF	—	Velocity controller P Gain, Actual P Gain=(Velocity Kp)/64
32	Velocity Ki	2	42	36	0x02EE0	0x0000~0x7FFF	—	Velocity controller I Gain, Actual I Gain=(Velocity Ki)/16384
33	LED Blink Period	1	44	38	0x2D	0x00~0xFE	RW	Alarm LED blink interval when Error detected according to • LED Policy t= 11.2[ms], 0x2D : 504[ms]
34	ADC Fault Check Period	1	45	39	0x2D	0x00~0xFE	RW	Temp/Voltage error check interval. Error decided when error status lasts longer than the check interval • t= 11.2[ms], 0x2D : 504[ms]
35	Packet Garbage Check Period	1	46	40	0x12	0x00~0xFE	RW	Garbage packet check interval. Error decided when error status lasts longer than the check interval • t= 11.2[ms], 0x12 : 201[ms]
36	Stop Detection Period	1	47	41	0x1B	0x00~0xFE	RW	Stepe detection check period, Servo stopped if stop lasts longer thank the check period. • t= 11.2[ms], 0x1B : 302[ms]
37	Overload Detection Period	1	48	42	0x96	0x00~0xFE	RW	Overload detection check period. No decision made if 0. Overload decided if overload lasts longer than the check period. t= 4[ms], 0x96 : 600[ms]
38	Stop Threshold	1	49	43	0x06	0x00~0xFE	RW	Servo is deemed to have stopped if position change is smaller than r(Stop Threshold) and lasts longer than r(Stop Detect Period)
39	Inposition Margin	1	50	44	0x06	0x00~0xFE	RW	Standard reference value for determining if goal position has been reached. If deviation is less than r(Inposition Margine), goal position reached.
40	Reserved	1	51	45	—	—	—	Reserved
41	Calibration Difference	1	52	46	0x00	Calibration Diff lower 1byte	RW	Calibration Diff : changed to 2byte. Save lower 8 bits following Byte order ※DRS-0602(-255~255, approximately ±40[deg])
42		1	53	47	0x00	Calibration Diff upper 1byte	RW	• Used for calibrating 0 point(Position : 16384) • Absolute position = position + r(Calibration Difference) • r(Calibration Difference) = Absolute position - 0point(16384) ※DRS-0602(-1495~1495, approximately ±40[deg])
43	Status Error	1	—	48	0x00	0x00~0x7F	RW	Can show 6 types of Error(Refer to Pg 35) ※DRS-0602 : 0x20(Driver fault) not supported, always 0
44	Status Detail	1	—	49	0x00	0x00~0x7F	RW	Error status description, shows 3 types of status (Refer to Page 35)
45	Aux 1	1	—	50	0x00	0x00~0x06	RW	Reset r(Absolute position) Refer to Page 25 0X01 : r(Absolute Position) revision by Potentiometer 0X02 : Set r(Absolute position) to 0 0X03 : Set r(Absolute position) to 9903(-180[deg]) 0X04 : Set r(Absolute position) to 16384(0[deg]) 0X05 : Set r(Absolute position) to 22865(180[deg]) 0X06 : Set r(Absolute position) to 32767
46	Reserved	1	—	51	0x00	—	—	Reserved

NO	Type	Bytes	EEP(ROM) ADDR	RAM ADDR	Default (DRS-0602)	Valid Range	RW	Description/Meaning
47	Torque Control	1	—	52	0x00	MASK : 0x60	RW	<ul style="list-style-type: none"> Torque control 0x40 : Break On, 0x60 : Torque On 0x00 : Torque Free When Torque enabled, Mode depends on r(Current Control Mode) before Torque On. <ul style="list-style-type: none"> ※ r(Current Control Mode) initialized to Position Control(0) after power on. ※ Torque On : Operation possible ※ Break On : Operation command(L_JOG, S_JOG) possible. Maintain Break status ※ Torque Free : Similar to Break On but joints can be moved easily
48	LED Control	1	—	53	0x00	0x00 ~ 0x07	RW	<p>Herkulex Servo LED control When applicable Bit is 1 = On, 0 = Off (0x01 : Green, 0x02 : Blue, 0x04 : Red) <ul style="list-style-type: none"> ※ When alarm activated by r(Status Error)& r(Alarm LED Policy), ignore r(Led Control) write value </p>
49	Voltage	1	—	54	—	0~200	RO	Input voltage ADC, r(Voltage) number expressed is 10 x voltage value, expressed to 1 decimal point. <ul style="list-style-type: none"> ※DRS-0602 : provides value converted to voltage
50	Temperature	1	—	55	—	0~110	RO	Current temperature ADC, expresses celsius using decimal number <ul style="list-style-type: none"> ※DRS-0602 : provides value converted to temperature
51	Current Control Mode	1	—	56	0x00	0 ~ 1	RO	Current Herkulex Servo control method Control Method can be changed using L_JOG / S_JOG CMD Packet. When Torque ON using r(Torque Control), Herkulex Servo refers to r(Current Control Mode) 0 : Position Control 1 : Turn/Velocity Control(Infinite turn)
52	Tick	1	—	57	—	0x00 ~ 0xFF	RO	Expresses actual servo tick time, tick time can be changed from 0~255 1 = 11.2[ms], upto 2.8672[sec] can be expressed
53	Calibrated Position	2	—	58	—	—	RO	Calibrated position Raw Data Current Calibrated Position Engineering value
54	Absolute Position	2	—	60	—	—	RO	Absolute position Raw Data Current Not Calibrated Position Engineering value Angle = (Absolute Position) x 0.02778
55	Differential Position	2	—	62	—	—	RO	Exponent showing speed <ul style="list-style-type: none"> ※1 unit DRS-0602(0.62[deg/s])
56	PWM	2	—	64	0x0000	—	RO	Size of the current energy output
57	Absolute 2nd Position	2	—	66	—	—	RO	Potentiometer absolute position Raw Data <ul style="list-style-type: none"> ※1unit DRS-0602(0.163[deg])
58	Absolute Goal Position	2	—	68	—	—	RO	Absolute goal position Raw Data Not Calibrated Goal Position Engineering value, User assigned Goal Position
59	Absolute Desired Trajectory Position	2	—	70	—	—	RO	Current intermediate goal position based on speed profile. Raw data r(Absolute Desired Trajectory Position) is current goal position.
60	Desired Velocity	2	—	72	0x0000	—	RO	Raw Data r(Desired Velocity) of current goal speed based on speed Profile is the speed value required at present time. <ul style="list-style-type: none"> ※1unit DRS-0602(0.034[deg/s])

※ 2 Byte variable Byte Order : (Little Endian) saves Upper Byte value (MSB) in higher address
[Example] : e(Position Kp) Address is 30~31. To enter 0x1234(4460), save in reverse order as follows
Address(30)= 0x34, Address(31)=0x12.

※ Intel Processors and Alpha processors use Little Endian, Most of RISC based computers and Motorola processors use Big Endian.

► Acceleration Ratio(RAM Register Address 8)

Acceleration Ratio can be adjusted by setting the register value. Change in Acceleration ratio is applied to Deceleration ratio identically. Default is shown as ladder type graph.

※ Decreasing the acceleration ration will lead to drastic change is speed accompanied by vibration (Blue graph). Increasing the acceleration ratio will show smooth slow speed increase but also lead to drasic change at the peak in the middle (Red graph). Due to these reasons, most of the controllers use ladder shaped (Yellow graph) speed profile.

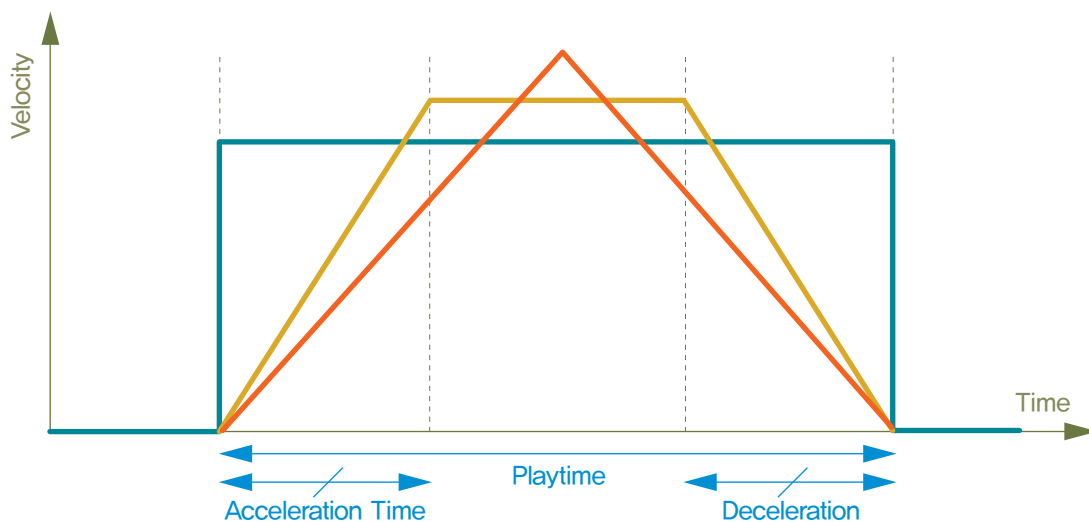

► Maximum Acceleration Time(RAM Register Address 9)

Expresses maximum acceleration time, 1 is = 11.2ms. Maximum acceleration time is 2.844s when r(Maximum Acceleration Time) is 254.

※ Speed profile is rectangle when r(Maximum Acceleration Time) is 0.

► Torque Control(RAM Register Address 52)

- Controls Torque enable state
- 0x40 : Break On
- 0x60 : Torque On
- 0x00 : Torque Free
- When torque is enabled, mode depends on the "Current Control Mode". Torqure will be enabled to prior r(Current Control Mode) state.

※ r(Current Control Mode) initialized to Position Control(0) when servo is first powered on.

※ (I_JOG, S_JOG) commands will function only during Torque On state

※ (I_JOG, S_JOG) commands will not function during Break On state (electrical Break).

※ Joints can be easily manipulated during Torque Free state

▶ LED Control(RAM Register Address 53)

Controls LEDs installed on Herkulex Servo.

- When Bit value below is 1 = On, 0 = Off
- 0x01 : Green
- 0x02 : Blue
- 0x04 : Green

※ When Alarm LED is activated by r(Status Error) and r(Alarm LED Policy), value in r(LED Control) is ignored.

▶ Voltage(RAM Register Address 54)

Decimal number with input voltage x 10. (1 refers to 0.1V)

▶ Temperature(RAM Register Address 55)

Expresses Herkulex internal temperature in celcius.

▶ Current Control Mode(RAM Register Address 56)

Shows the current control method of Herkulex Servo, I_JOG / S_JOG CMD Packet is used to change the control method.

- When r(Torque Control) is used to change the HerkuleX servo state to Torque On, Herkulex Servo first referst to r(Current Control Mode) before Torque On. For example, default mode of the servo when it is first powered on is Position Control Mode and when the servo state is changed to Torque On, mode remains at position Control Mode. To change the control mode to Turn/Velocity Control Mode, change the torque state to Torque Off, and then use I_JOG / S_OJG CMD to switch to Turn/Velocity Control Mode. Mode will remain at Turn/Velocity Control mode when torque state is changed to Torqure ON.
 - 0 : Position Control
 - 1 : Turn / Velocity Control
- ※ Turn / Velocity Control : Refers to Infinite Turn Mode

▶ Tick(RAM Register Address 57)

Shows actual length of the Herkulex Servo tick time. Tick time can be changed from 0 ~ 255, tick time reverts back to 0 after 255.

1 = 11,2ms, 255 = 2,856s.

▶ Calibrated Position(RAM Register Address 58)

Shows Calibrated position Raw Data. Relationship between Calibrated Position and Absolute Position is as follows.

- Calibrated Position = Absolute Position – r(Calibration Difference)
- Angle(Degree) = (Position Raw Data – 9903) X 0,02778

► Absolute Position(RAM Register Address 60)

Shows uncalibrated current position Raw Data. Relationship between Raw Data and actual angle is as follows

$$\text{Angle(Degree)} = (\text{Position Raw Data} - 9903) \times 0.02778$$

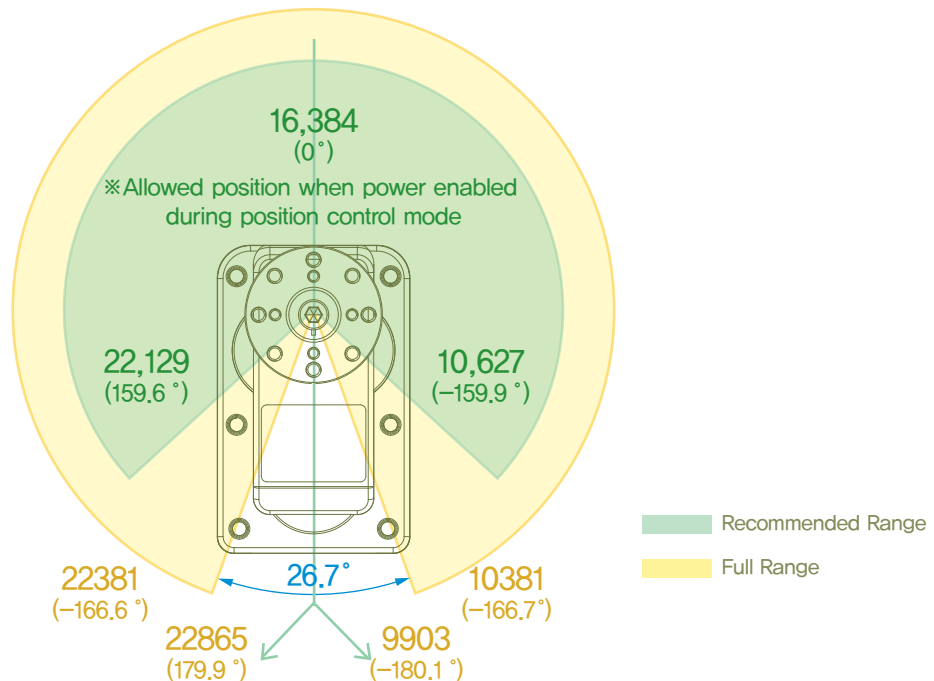

► Differential Position(RAM Register Address 62)

Shows speed measurement.

$$\text{r(Diff Position)} 1 = 0.62 \text{deg/sec}$$

► PWM(RAM Register Address 64)

Shows current Torque Raw Data, maximum value is 1023.

► Absolute Goal Position(RAM Register Address 68)

Shows uncalibrated goal position Raw Data. Uncalibrated value showing user designated goal position.

► Absolute Desired Trajectory Position(RAM Register Address 70)

- Uncalibrated goal position Raw Data from current position. To arrive at the user designated goal position, Herkulex Servo speed profile automatically plans out the trajectory to the goal position. Absolute Desired Trajectory Position refers to an intermediate goal position from the current position.
- Diagram in the next pages shows the relationship between the Absolute Goal Position and Absolute Desired Trajectory Position.

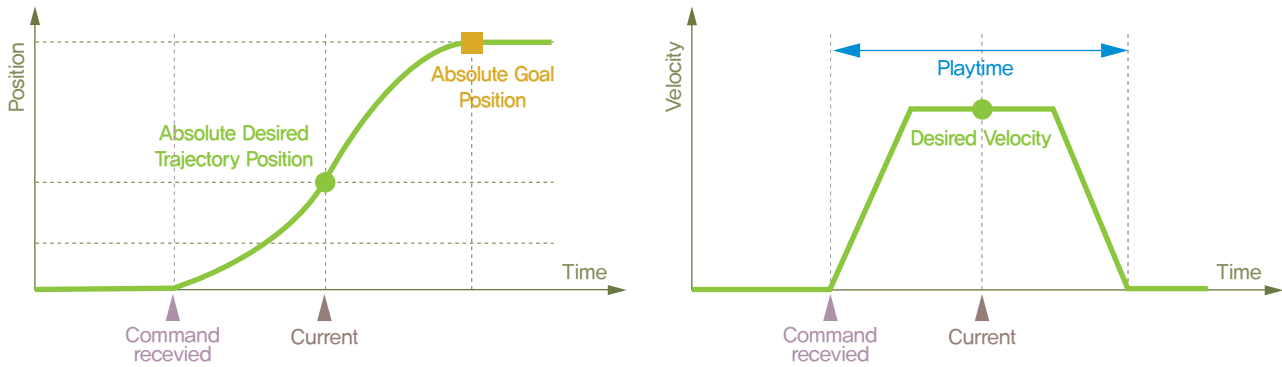

► ACK Policy(RAM Register Address 14)

Set Ack Packet reply policy when Request Packet received.

- 0 : Do not reply to any Request Packet.
- 1 : Only reply to Read CMD.
- 2 : Reply to all Request Packet.

※ CMD is STAT, ACK Packet will be sent regardless of r(ACK Policy)

※ Normally, reply is not sent when pID is 254(Broadcast pID). Except when CMD is STAT in which case reply is sent.

► Alarm LED Policy(RAM Register Address 2)

Set Alarm LED policy when Error detected.

- Bblink LED when (r(LED Policy) & r(Status Error)) is True. Blink interval is set by r(LED Blink Period).
- When (r(LED Policy) & r(Status Error)) is True, Any values entered in r(LED Control) will be ignored to prevent confusion with Error state.
- Error status in r(Status Error) must be deactivated first in order for r(LED Control) to function properly.

► Torque Policy(RAM Register Address 3)

Set Torque Off policy when Error detected.

- When (r(Servo Policy) & r(Status Error)) is True, Torque is released (Torque Off) and will not return to Torque On state regardless of value being entered in r(Torque Control).
- Servo does not automatically revert to Torque On state even after r(Status Error) is deactivated. Enable Torque On using r(Torque Control) after deactivating r(Status Error) to change to Torque On state.

※ 'A&B' : Bit And Operator, 1(True) only when A&B is 1(True)

► **Maximum Temperature(RAM Register Address 5)**

Express maximum operating Herkulex temperature. Show celcius using decimal number.

- When Herkulex Servo temperature $r(\text{Temperature})$ exceeds $r(\text{Max Temperature})$, "Exceed Temperature Limit" is set in $r(\text{Status Error})$.
- Alarm LED and Torque state can be changed using $r(\text{LED Policy})$ and $r(\text{Servo Policy})$.
- Default value is 0xDF(approximately 80°C).

► **Minimum Voltage(RAM Register Address 6)**

Express minimum input voltage x 10 using decimal number

- When Herkulex Servo input voltage $r(\text{Voltage})$ is below $r(\text{Min Voltage})$, "Exceed Voltage Limit" is set in $r(\text{Status Error})$. Alarm LED and Torque state can be changed using $r(\text{LED Policy})$ and $r(\text{Servo Policy})$.
- Default value is 92(approximately 9.2V).

► **Maximum Voltage(RAM Register Address 7)**

Express maximum input voltage x 10 using decimal number.

- When Herkulex Servo input voltage $r(\text{Voltage})$ exceeds $r(\text{Max Voltage})$, "Exceed Voltage Limit" is set in $r(\text{Status Error})$. Alarm LED and Torque state can be changed using $r(\text{LED Policy})$ and $r(\text{Servo Policy})$.
- Default value is 180(approximately 18V).

► **Overload PWM Threshold(RAM Register Address 18)**

Overload threshold. External force is divided into 0~1023 steps.

- Overload is detected when external force larger than $r(\text{Overload PWM Threshold})$ is exerted on the servo longer than $r(\text{Overload detect period})$.
- Overload does not occur if $r(\text{Overload PWM Threshold})$ is larger than 1023.

► **Minimum Position(RAM Register Address 20)**

Minimum operating angle Raw Data.

- When requested position angle is less than $r(\text{Min Position})$, "Exceed Allowed Position Limit" is set in $r(\text{Status Error})$ and actual operation is limited to $r(\text{Position Min})$.
- Default value is 0x2A(approximately -159.8°).

► Maximum Position(RAM Register Address 22)

Maximum operating angle.

- When requested position angle is greater than r(Max Position), "Exceed Allowed Position Limit" is registered in r(Status Error) and actual operation is limited to r(Max Position).
- Default value is 0x7D5(approximately 159.8 °).

► Position Kp(RAM Register Address 24)

Shows the proportional Gain. Increasing the Position Kp will increase the response time but servo will overreact (vibrate) if the value is set too high.

► Position Kd(RAM Register Address 26)

Shows the derivative Gain. Increasing the Position Kd value will suppress overreaction (vibration) due to Position Kp but servo may become unstable if the value is set too high.

► Position Ki(RAM Register Address 28)

Shows the integral Gain. Applied to correct small offset in Steady State(normal state). May influence system response if value is set too large.

► Position Feedforward Kd(RAM Register Address 30)

Shows position Feedforward 1st Gain. Applied to increase Herkulex Servo response time.

► Position Feedforward Kdd(RAM Register Address 32)

Shows position Feedforward 2nd Gain. Applied to increase Herkulex Servo response time

► LED Blink Period(RAM Register Address 38)

Shows the Alarm LED blink rate when Error detected according to r(LED Policy).

1 = 11.2ms.

Default value is 0x2D(approximately 504ms).

► ADC Fault Check Period(RAM Register Address 39)

Temperature/Input voltage error check interval, 1=11.2ms. Error detected when Temperature/Input voltage error lasts longer than the check interval.

Default value 0x2D(approximately 504ms).

► Packet Garbage Check Period(RAM Register Address 40)

Incomplete Packet check interval, 1= 11.2ms, Incomplete Packet will be deleted if it remains longer than the check interval.

Default value is 0x12(approximately 201ms).

► Stop Detection Period(RAM Register Address 41)

Herkulex Servo stop check interval, $t = 11.2\text{ms}$. Stop detected if stop lasts longer than the check interval.

Default value is $0x1B$ (approximately 302ms).

► Overload Detection Period(RAM Register Address 42)

Herkulex Servo Overload check interval $t = 11.2\text{ms}$. Overload detected if overload lasts longer than the check interval.

Default value is $0x96$ (approximately 1.68s).

► Stop Threshold(RAM Register Address 43)

Servo is deemed to have stopped if position change is less than $r(\text{Stop Threshold})$. If stop lasts longer than the time set in $r(\text{Stop Detection Period})$, servo is judged to have stopped.

► Inposition Margin(RAM Register Address 44)

Standard value to determine if the goal position has been reached. Goal position is deemed to have been reached in the deviation from the goal position is less than $r(\text{Inposition Margin})$.

► Saturator Offset, Saturator Slope(RAM Register Address 11 and 12)

Saturator Offset, Saturator Slope work in similar manner to PWM but ability to control the limit per each section allow for design of more accurate Saturator to provide flexible and elastic response to external forces. Graph below shows PWM with several different settings. Thick white line show the PWM without Saturator Offset and Slope settings, red line shows the actual PWM output with Saturator Offset and Slope set. Blue dotted line shows the boundary of the force restrained by the Saturator. Restrain on PWM value increases near the goal position and decreases when away from the goal position. The effect on PWM is similar to having a spring installed near the goal position with increasing strength the further away from the goal position. Assuming Herkulex Servo is stopped at the goal position, Saturator allows flexible response to external force and also provides an ability to hold a delicate object without breaking it

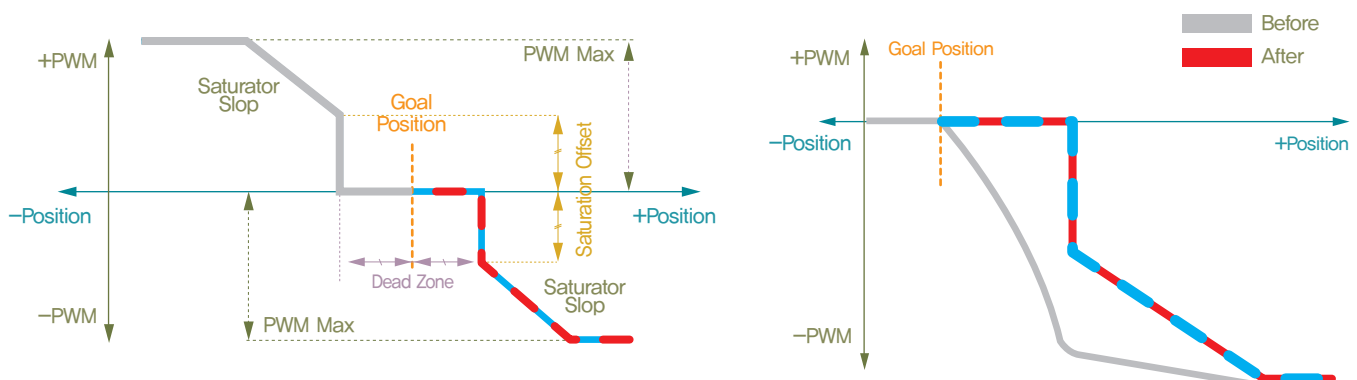

► PWM Offset(RAM Register Address 14)

When PWM 0 point is moved, PWM will increase output by the amount of the Offset. This can be used to act as a compensator in a system where load is one sided (Ex: Gravity).

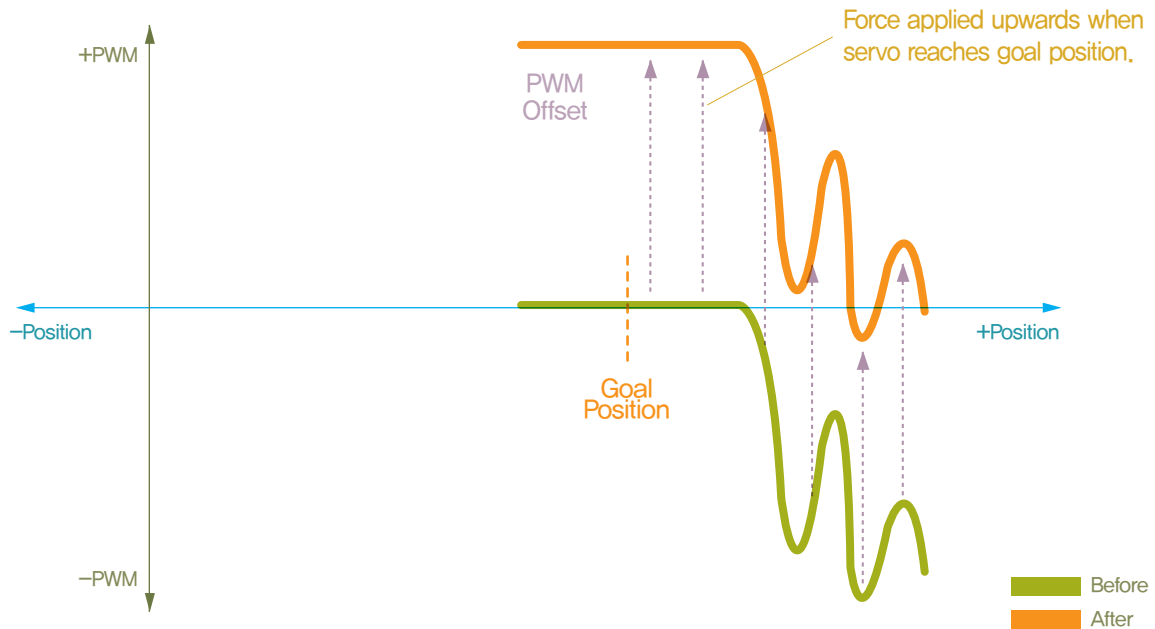

► Minimum PWM(RAM Register Address 15)

PWM value does not output below $r(\text{Min. PWM})$. Minimum PWM is used to compensate for jerky movement due to tight fitting or friction when designing system using HerkuleX Servos. However, assigning Minimum PWM value that is too large may lead to unstable system.

► Maximum PWM(RAM Register Address 16)

PWM value does not output above $r(\text{Max. PWM})$. Battery life could be increased by limiting the maximum output but using this value will decrease the HerkuleX Servo Torque and speed.

► Relationship between Saturator & PWM

PWM expresses HerkuleX Servo output. As seen in the graph below, there are many parameters controlling HerkuleX Servo output. These parameters can be manipulated to build more efficient system using HerkuleX Servos. Refer to the detailed description of each parameter for more information concerning parameters.

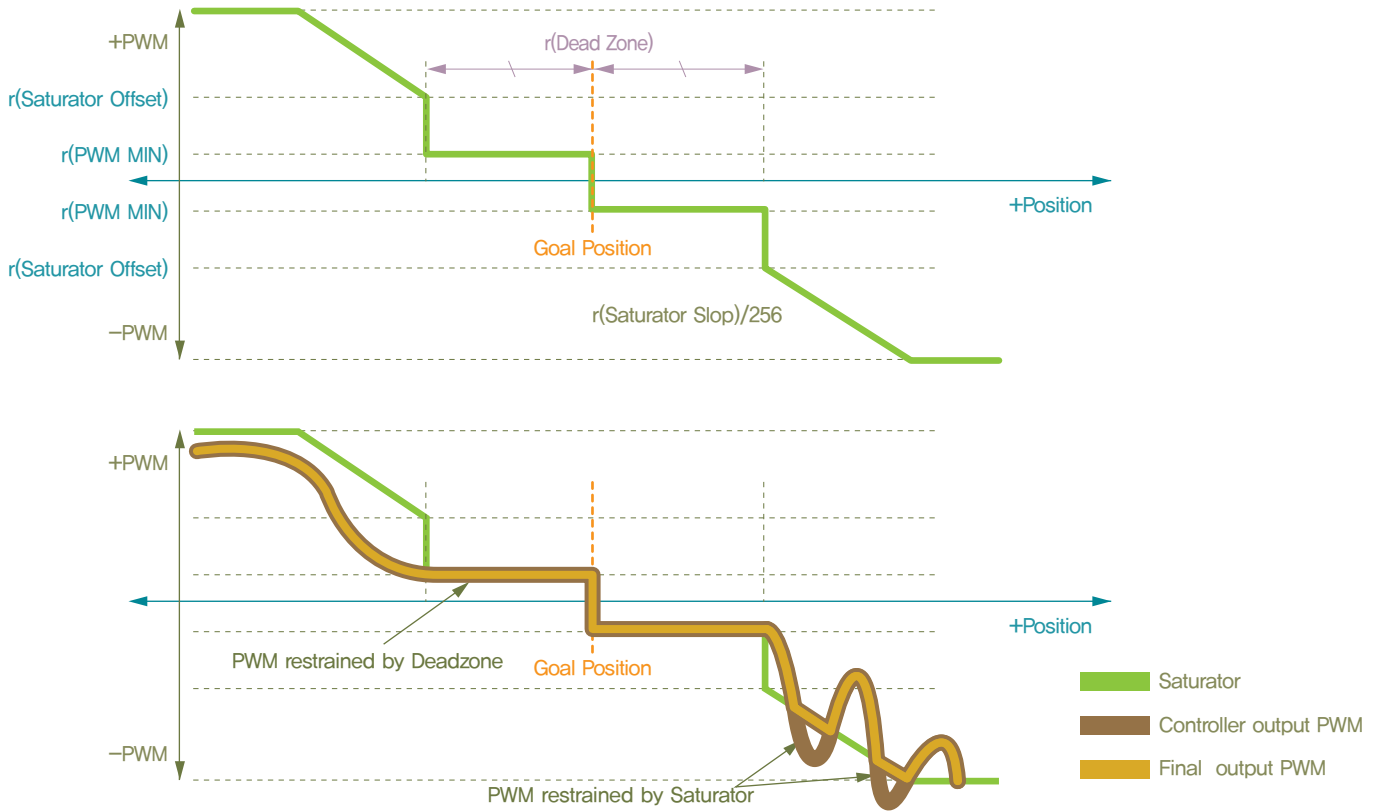

► Calibration Difference(RAM Register Address 46 & 47)

Used for calibrating 0 point (standard), Used to make adjustments to compensate for assembly variations when HerkuleX Servos are used to build a system or to move the 0 point, Clibrated difference is calculated using following formulat.

$$\text{Calibrated Position} = \text{Absolute Position} - \text{Calibration Difference}$$

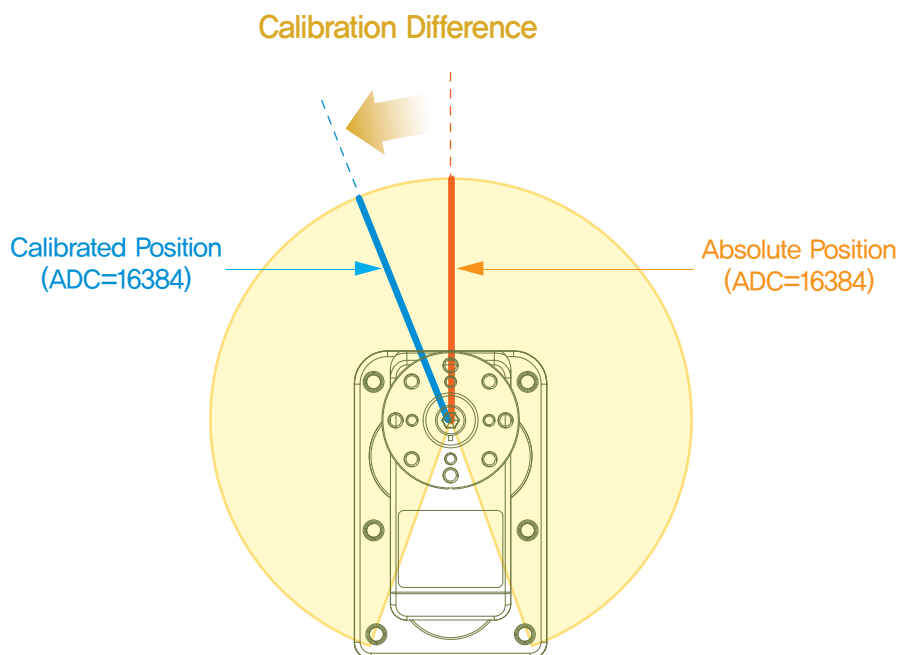

► Status Error, Status Detail(RAM Register Address 48 & 49)

Status																	
r(Status Error)					r(Status Detail)												
Bits	7	6	5	4	3	2	1	0	Bits	7	6	5	4	3	2	1	0
Bits	Value	Comment		Bits	Value	Comment											
0	0X01	Exceed Input Voltage limit		0	0X01	Moving flag											
1	0X02	Exceed allowed POT limit		1	0X02	Inposition flag											
2	0X04	Exceed Temperature limit		2	0X04	Checksum Error											
3	0X08	Invalid Packet		3	0X08	Unknown Command											
4	0X10	Overload detected		4	0X10	Exceed REG range											
5	0X20	Reserved		5	0X20	Garbage detected											
6	0X40	EEP REG distorted		6	0X40	Torque ON											
7	0X80	reserved		7	0X80	reserved											

- ※ r(Alarm LED Policy, Torque Policy) : Same as above
- ※ r(Alarm LED Policy) : When error occurs with checked bit, LED(RED) blinks
- ※ r(Torque Policy) : When error occurs with checked bit, Torque is released to Freerun state.

- ※ When invalid Packet occurs, detailed information is recorded in r(Status Detail)
- ※ Moving/Inposition/Torque ON flag has Read only property.

- Gold lines above point to error details when r(Status Error) refers to Invalid Packet(0x08).
- Invalid Packet can have 5 different causes with 4 shown in r(Status Detail) and one other.
- Parts of r(Status Detail) have Read only property but can be written to according to Protocol. Read only values are ignored and not written to.

5. Command Set

In order to control HerkuleX Servo, CMD is sent to HerkuleX Servo in Binary format from the controller. HerkuleX Servo has 9 different CMDs. After receiving Request Packet with CMD, HerkuleX Servo will perform the requested task and return the result to the controller in ACK Packet format.

5-1. [To HerkuleX Servo Module] – Request Packet

Type	CMD	Description/Meaning
EEP_WRITE	0x01	<ul style="list-style-type: none"> Write Length # of values to EEPROM Register Address Data length: Address & Length each 1Byte + Length Byte
EEP_READ	0x02	<ul style="list-style-type: none"> Read Length # of values from EEPROM Register Address Data length is 2 May not reply depending on r(ACK Policy)
RAM_WRITE	0x03	<ul style="list-style-type: none"> Write Length number of values to RAM Register Address Data length: Address & Length each 1Byte + Length Byte
RAM_READ	0x04	<ul style="list-style-type: none"> Read Length number of values from RAM Register Address Data length is 2 May not reply depending on r(ACK Policy)
L_JOG	0x05	<ul style="list-style-type: none"> Able to send JOG command to maximum of 43 HerkuleX Servos Send command to multiple HerkuleX Servos simultaneously, Assign position/time to all HerkuleX Servos individually. Assign Playtime to HerkuleX Servos individually L_JOG requires 5bytes of data per 1 HerkuleX Servo. 50Bytes of Optional Data length is need to send command to 10 HerkuleX Servos. Refer to Page 40 for L_JOG format
S_JOG	0x06	<ul style="list-style-type: none"> Alle to send JOG commad to maximum of 53 HerkuleX Servos Send command to multiple HerkuleX Servos simultaneously, All HerkuleX Servos have identical playtime, All HerkuleX Servos arrive at goal position at same time. S_JOG requires Playtime 1Bytes and 4Bytes for each HerkuleX Servo. 41 Bytes of Optional Data Length needed to send command to 10 HerkuleX Servos Refer to Page 41 for S_JOG_TAG format
STAT	0x07	<ul style="list-style-type: none"> Request HerkuleX Servo status r(Status Error, Status Detail) Always send reply to STAT Packet regardless of r(ACK Policy)
ROLLBACK	0x08	<ul style="list-style-type: none"> Change all EEPROM Register values to Factory Default value Apply changes after reset. e(ID, Baud Rate, Calibration Difference)can be exempted from Factory Default initialization using ID Skip, Baud Skip, Cali Skip. Depending on Cali Skip setup, e(Calibration Difference) can be exempted.
REBOOT	0x09	<ul style="list-style-type: none"> Reboot HerkuleX Servo

5-2. [To Controller(ACK)] – ACK Packet

Type	CMD	Description/Meaning
EEP_WRITE	0x41	<ul style="list-style-type: none"> Reply packet to CMD(0x01) Default is no reply. Reply possible by changing r(ACK Policy) setting.
EEP_READ	0x42	<ul style="list-style-type: none"> Reply length number of values from EEPROM Register Address May not reply depending on r(ACK Policy) setting.

Type	CMD	Description/Meaning
RAM_WRITE	0x43	<ul style="list-style-type: none"> • Reply packet to CMD(0x03) • Default is no reply. Reply possible by changing r(ACK Policy) setting.
RAM_READ	0x44	<ul style="list-style-type: none"> • Reply length number of values from RAM register Address • May not reply depending on r(ACK Policy) setting.
I_JOG	0x45	<ul style="list-style-type: none"> • Reply packet to CMD(0x05) • Default is no reply. Reply possible by changing r(ACK Policy) setting.
S_JOG	0x46	<ul style="list-style-type: none"> • Reply packet to CMD(0x06) • Default is no reply. Reply possible by changing r(ACK Policy) setting.
STAT	0x47	<ul style="list-style-type: none"> • r(Status Error, Status Detail) reply, Always reply regardless of r(Ack Policy)
ROLLBACK	0x48	<ul style="list-style-type: none"> • Reply packe to CMD(0x08) • Default is no reply. Reply possible by changing r(ACK Policy) setting.
REBOOT	0x49	<ul style="list-style-type: none"> • Reply packet to CMD(0x09) • Default is no reply. Reply possible by changing r(ACK Policy) setting.

- ※ ACK option can be changed by changing r(ACK Policy)
- ※ ACK Packet CMD is Request Packet CMD + 0x40
- ※ Last 2 Bytes of ACK Packet includes r(Status Error, Status Detail)

6. Command Examples

6-1. EEP_READ

From HerkuleX Servo ID 253, request 4Bytes of data from EEP Register with 0x1E Address. 4Bytes in EEP Register from address 0x1E are e(Position Kp) and e(Position Kd).

EEP_READ	Header		Packet Size	pID	CMD
	0	1	2	3	4
	0xFF	0xFF	9	Herkulex Servo ID	0x02
Example1	0xFF	0xFF	0x09(9)	0xFD	0x02

EEP_READ	Check Sum1	Check Sum2	Data	
	5	6	7	8
	(Refer to Checksum)		Data[0] (Address)	Data[1] (Length)
Example1	0xEC	0x12	0x1E	0x04

EEP READ

Request to read Length number of values from the Address in EEP Register. Data length is 2 Bytes (Address 1Byte + Length 1Byte).

Packet Size	pID	EEP READ CMD
7(Standard Size) + 2(Data length)	HerkuleX Servo with ID 0xFD(253)	0x02 (Refer to Page 36)

CHECKSUM Formula

$$\text{Check Sum1} = (\text{PacketSize} \wedge \text{pID} \wedge \text{CMD} \wedge \text{Data}[0] \wedge \text{Data}[1] \wedge \dots \wedge \text{Data}[n]) \& 0xFE$$

$$\text{Check Sum2} = (\sim(\text{PacketSize} \wedge \text{pID} \wedge \text{CMD} \wedge \text{Data}[0] \wedge \text{Data}[1] \wedge \dots \wedge \text{Data}[n])) \& 0xFE$$

DATA[0]

Refers to starting Address of EEP Register being READ. 0x1E(30) in the example is starting address of Position Kp.

DATA[1]

Data[1] refers to number of Bytes to be Read from the starting address. 0x04 in the example means 4Bytes will be read. In other words, 4 Bytes will be read from the Position Kp starting address. Position Kp (2Bytes variable) and Position Kd(2Bytes variable) will be Read.

ACK Packet

EEP_READ	Header		Packet Size	pID	CMD	Check Sum1	Check Sum2
	0	1	2	3	4	5	6
ACK of Example1	0xFF	0xFF	0x0F	0xFD	0x42	0x4C	0xB2
Data							
7	8	9	10	11	12	13	14
Data[0] (Address)	Data[1] (Length)	Data[2]	Data[3]	Data[4]	Data[5]	Data[4] (Status Error)	Data[5] (Status Detail)
0x1E	0x04	0xB8	0x01	0x40	0x1F	0x00	0x00

- CMD : Request Packet CMD(0x02)+ 0x40, reply with 0x42
- e(Position Kp) : 440(0x1B8)
- Position Kd : 8000(0x1F40)
- Last 2 Bytes of all ACK Packet contain Status Error and Status Detail

6-2. EEP_WRITE

ID(253), Write Kp = 200(0x00C8), Kd = 1000(0x03E8) values to e(Position Kp / Kd(Address 0x1E=30, 4Bytes Register))

EEP_WRITE	Header		Packet Size	pID	CMD	Check Sum1	Check Sum2
	0	1	2	3	4	5	6
	0xFF	0xFF	7+(2+Length)	Herkulex Servo ID	0x01	(Refer to Checksum formula)	
Example1	0xFF	0xFF	0x0D(13)	0xFD	0x01	0XC8	0X36
Data							
7	8	9	11	12	13		
Data[0] (Address)	Data[1] (Length)	Data[2]	Data[3]	Data[4]	Data[5]		
0x1E	0x04	0XC8	0X00	0XE8	0X03		

Data[2] ~ Data[5]

Data[2] and Data[3] refers to e(Position Kp), Data[4] and Data[5] refers to e(Position Kd). Following Little Endian rule, Byte should be written in reverse order.

※ Refer to Page 25 for Little Endian.

EEP Register

To apply changes to EEP Register value, reboot Herkulex Servo.

6-3. RAM_WRITE

Example 1

ID(253), r(LED Control), Request green LED ON from Address(0x35(53))

Example 2

ID(253), r(Status Error, Status Detail), Clear Address(0x30(48)) with "0".

Example 3

ID(253), r(Torque Control), Write 0x60 to Address(0x34(52)) to request Torque On.

※ Implement Torque ON prior to (I_JOG, S_JOG) command.

RAM_WRITE	Header		Packet Size	pID	CMD	Check Sum1	Check Sum2
	0	1	2	3	4	5	6
	0xFF	0xFF	7+(2+Length)	HerkuleX Servo ID	0x03	(Refer to Checksum Formula)	
Example1	0xFF	0xFF	0x0A(10)	0xFD	0x03	0xC0	0x3E
Example2	0xFF	0xFF	0x0B(11)	0xFD	0x03	0xC6	0x38
Example3	0xFF	0xFF	0x0A(10)	0xFD	0x03	0xA0	0x5E
Optional Data							
	7	8	9	10			
	Data[0] (Address)	Data[1] (Length)	Data[2]	Data[3]			
	0x35	0x01	0x01	—			
	0x30	0x02	0x00	0x00			
	0x34	0x01	0x60	—			

6-4. RAM_READ

Example 1

ID(253), Read 1Byte fromAddress 0x35(53), r(LED Control) is the Register of the Address

RAM_READ ACK

Reply Packet to RAM_READ(CMD 0x04), reply to CMD with 0x44. Last 2 Bytes of all ACK Packet contain r(Status Error) and r(Status Detail). ACK Packet reply option can be changed by r(ACK Policy).

Data[2]

r(LED Control) value 0x01 means Green LED is On

Data[3]

Data[3] is Status Error : No error, Data[4] is 0x42 : Torque On and Inposition,

	Header		Packet Size	pID	CMD	Check Sum1	Check Sum2
RAM_READ	0	1	2	3	4	5	6
	0xFF	0xFF	7+(2+Length)	HerkuleX Servo ID	0x03	(Refe to Checksum Formula)	
Example1	0xFF	0xFF	0x09(9)	0xFD	0x04	0xC4	0x3A
RAM_READ ACK	0xFF	0xFF	0x0C(12)	0xFD	0x44	0xC2	0x3C
Optional Data							
	7	8	9	10	11		
	Data[0] (Address)	Data[1] (Length)	Data[2]	Data[3]	Data[4]		
	0x35	0x01	–	–	–		
	0x35	0x01	0x01	0x00	0x42		

6–5. I_JOG

Example 1

ID(253), position control, Goal position 512, Green LED On, Playtime(60 : 672ms)

Example 2

ID(253), Infinte turn, Goal speed 320, Blue LED On, Playtime(60 : 672ms)

※ Unlike the previous model, DRS–0602 is equipped with Velocity controller.

Desired velocity 1 refers to 0.62[deg/s].

When Desired velocity value exceeds maximum DRS–0602 speed, Velocity controller speed error accumulates and could lead to delay in responding to other speed command.

I_JOG	Header		Packet Size	pID	CMD	Check Sum1	Check Sum2
	0	1	2	3	4	5	6
	0xFF	0xFF	7+(5x number of JOG)	Herkulex Servo ID	0x05	(Refer to Checksum Formula)	
Example1	0xFF	0xFF	0x0C(12)	0xFD	0x05	0x32	0xCC
Example2	0xFF	0xFF	0x0C(12)	0xFD	0x05	0x7E	0x80
Optional Data							
7	8	9	10	11			
I_JOG_S(0)							
JOG(LSB)	JOG(MSB)	SET	ID	playtime			
0x00	0x02	0x04	0xFD	0x3C			
40	0x01	0x0A	0x0A	0x3C			

- Refer to Packect structure below for meaning of each Bit in I_JOG
- Structure shown below used for convenience
- Declare LSB(Least Significant Bit) Bit value first
- In Example1, SET(0x04) refers to position control, Green LED On

```

typedef struct
{
    int iJogData : 15;
    unsigned int uiReserved1 : 1;

    unsigned int uiStop : 1;
    unsigned int uiMode : 1; //0 : Position control
    unsigned int uiLED : 3; //Green, Blue, Red
    unsigned int uiJogInvalid : 1;
    unsigned int unDisableVOR : 1;
    unsigned int uiReserved2 : 1;

    unsigned int ucID : 8;

    unsigned char ucJogTime_ms;
} IJOG_TAG

```

- ※ DRS-0602: un Disable VOR added. When suppressing VOR(Velocity Override) '1' VOR provides continuity between current speed and new speed set by new command.
- ※ Bit Variable Size or Bit Field could show difference depending on the Compiler or Compiler setting. Example above shows Bit Variable Size 16. Also, Structure Byte Align of Processors could be different. Our example uses 1Byte Align as reference.

6-6. S_JOG

Example 1

ID(253), Position control, Goal position 512, Red LED On, Playtime(60 : 672ms)

Example 2

ID(253), Infinite turn, Goal speed 704, Blue LED On, Playtime(60 : 672ms)

- ※ Unlike the previous model, DRS-0602 is equipped with Velocity controller. Desired velocity 1 refers to 0.62[deg/s]. When Desired velocity value exceeds maximum DRS-0602 speed, Velocity controller speed error accumulates and could lead to delay in responding to other speed command.

S_JOG	Header		Packet Size	pID	CMD	Check Sum1	Check Sum2
	0	1	2	3	4	5	6
	0xFF	0xFF	7+(5xL_number of JOG)	Herkulex Servo ID	0x06	(Refer to Checksum Formula)	
Example1	0xFF	0xFF	0x0C(12)	0xFD	0x06	0x30	0xCE
Example2	0xFF	0xFF	0x0C(12)	0xFD	0x06	0xFE	0x00
Optional Data							
7	8	9	10	11			
PLAY TIME	S_JOG_S(0)						
	JOG(LSB)	JOG(MSB)	SET	ID			
0x3C(60)	0x00	0x02	0x04	0xFD			
0x3C(60)	40	0x01	0x0A	0x0A			

- Refer to Packect structure below for meaning of each Bit in S_JOG
- Structure shown below used for convenience
- Declare LSB(Least Significant Bit) Bit value first
- In Example1, SET(0x04) refers to position control, Red LED On

```

typedef struct
{
    int iJogData : 15;
    unsigned int uiReserved1 : 1;

    unsigned int uiStop : 1;
    unsigned int uiMode : 1; //1 : Speed Control
    unsigned int uiLED : 3; //Green, Blue, Red
    unsigned int uiJogInvalid : 1;
    unsigned int unDisableVOR : 1;
    unsigned int uiReserved2 : 1;
    unsigned int uiReserved2 : 1;

    unsigned int ucID : 8;
} SJOG_TAG

```

- ※ DRS-0602: un Disable VOR added. When suppressing VOR(Velocity Override) '1' VOR provides continuity between current speed and new speed set by new command.
- ※ Bit Variable Size or Bit Field could show difference depending on the Compiler or Compiler setting. Example above shows Bit Variable Size 16. Also, Strcuture Byte Align of Prcessors could be different. Our example uses 1Byte Align as reference.

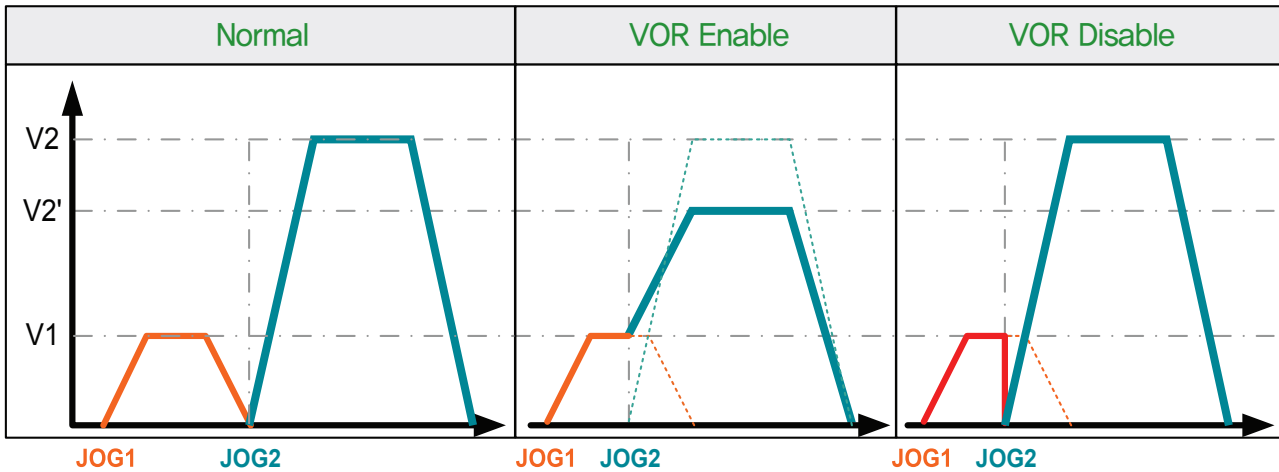

Perform JOG2 after completing JOG1	Perform JOG2 prior to completing JOG1
<ul style="list-style-type: none"> – Speed becomes “0” after completing JOG1 command – Recreate Velocity profile after receiving JOG2 command – Velocity profile is created without being influenced by each JOG command. 	<ul style="list-style-type: none"> – When VOR is Enabled Speed maintained at beginning of JOG2 command, smooth continuous movement – When VOR is Disabled Speed discontinuity at JOG2 command starting point. Discontinuity between motion to motion. <p>※ VOR : Velocity Override</p>

► I_JOG, S_JOG Packet Structure

I_JOG_TAG				S_JOG_TAG			
Type	Data		Comments	Type	Data		Comments
	Bytes	Bits			Bytes	Bits	
JOG	2	0	Case) JOG	JOG	2	0	Case) JOG
		1	Desired Goal POS			1	Desired Goal POS
		2	(Calibration applied)			2	(Calibration applied)
		3	Case) Infinite turn			3	Case) Infinite turn
		4	(Velocity control)			4	(Velocity control)
		5	Desired Velocity			5	Desired Velocity
		6	※ Infinite turn sign :			6	※ Infinite turn sign :
		7	Negative when 0X4000			7	Negative when 0X4000
		8	selected			8	selected,
		9				9	
		10				10	
		11				11	
		12				12	
		13				13	
		14	Sig@Infinite turn			14	Sig@Infinite turn
		15	Reserved=0			15	Reserved=0
SET	1	0	Stop flag	SET	1	0	Stop flag
		1	MODE			1	MODE
		2	LED GREEN			2	LED GREEN
		3	LED BLUE			3	LED BLUE
		4	LED RED			4	LED RED
		5	JOG Invalid(No Action)			5	JOG Invalid(No Action)
		6	Disable VOR			6	Disable VOR
		7	Reserved=0			7	Reserved=0
ID	1	Valid range : 0~0XFE	ID	1	Valid range : 0~0XFE		
Playtime	1	Valid range : 0~0XFE					

MODE	Comments
0	Position control JOG
1	Infinite turn

※ Unlike the previous model, DRS-0602 is equipped with Velocity controller. Desired velocity 1 refers to 0.62[deg/s]. When Desired velocity value exceeds maximum DRS-0602 speed, Velocity controller speed error accumulates and could lead to delay in responding to other speed command.

6-7. STAT

Request ID(253) Status

ACK Packet Data[0] refers to Status Error and means no Error

Data[1] refers to Status Detail, 0x40 is Torque On state

※ Refer to Page 35 for detailed information on Status Error and Status Detail.

STAT	Header		Packet Size	pID	CMD	Check Sum1	Check Sum2
	0	1	2	3	4	5	6
	0xFF	0xFF	7	Herkulex Servo ID	0x07	(Refer to Page 19)	
Example2	0xFF	0xFF	0x07	0xFD	0x07	0xFC	0x02
STAT ACK	0xFF	0xFF	0x09	0xFD	0x47	0xF2	0x0C
Optional Data							
	7	8					
	Data[0]	Data[1]					
	0x00	0x40					
	0x00	0x40					

6-8. ROLLBACK

ROLLBACK ID(253) ACK(Factory Default), Except ID and Baud Rate from initialization

ROLLBACK ACK

When r(ACK Policy) is set to "2" / "always reply", send ACK Packet

ROLLBACK	Header		Packet Size	pID	CMD	Check Sum1	Check Sum2
	0	1	2	3	4	5	6
	0xFF	0xFF	9	Herkulex Servo ID	0x08	(Refer to Page 19)	
Example1	0xFF	0xFF	0x09	0xFD	0x08	0xFC	0x02
ROLLBACK ACK	0xFF	0xFF	0x09	0xFD	0x48	0xBC	0x42
Optional Data							
	7	8					
	Data[0]	Data[1]					
	Skip Option1	Skip Option2					
	0x01	0x01					
	0x00	0x00					

※ Skip Option1 : 0x01(ID Skip), 0x10(Cali Skip)

※ Skip Option2 : 0x01(Baud Skip)

6-9. REBOOT

Reboot ID(254)

REBOOT ACK

When r(ACK Policy) is set to "2"/"Always reply", send ACK Packet.

REBOOT	Header		Packet Size	pID	CMD	Check Sum1	Check Sum2
	0	1	2	3	4	5	6
	0xFF	0xFF	7	Herkulex Servo ID	0x09	(Refer to Page 19)	
Example1	0xFF	0xFF	0x07	0xFD	0x09	0xF2	0x0C
REBOOT ACK	0xFF	0xFF	0x09	0xFD	0x49	0xBC	0x42
Optional Data							
7	8						
Data[0]	Data[1]						
-	-						
0x00	0x00						

Reference Material

HerkuleX Manager Kit Schematic

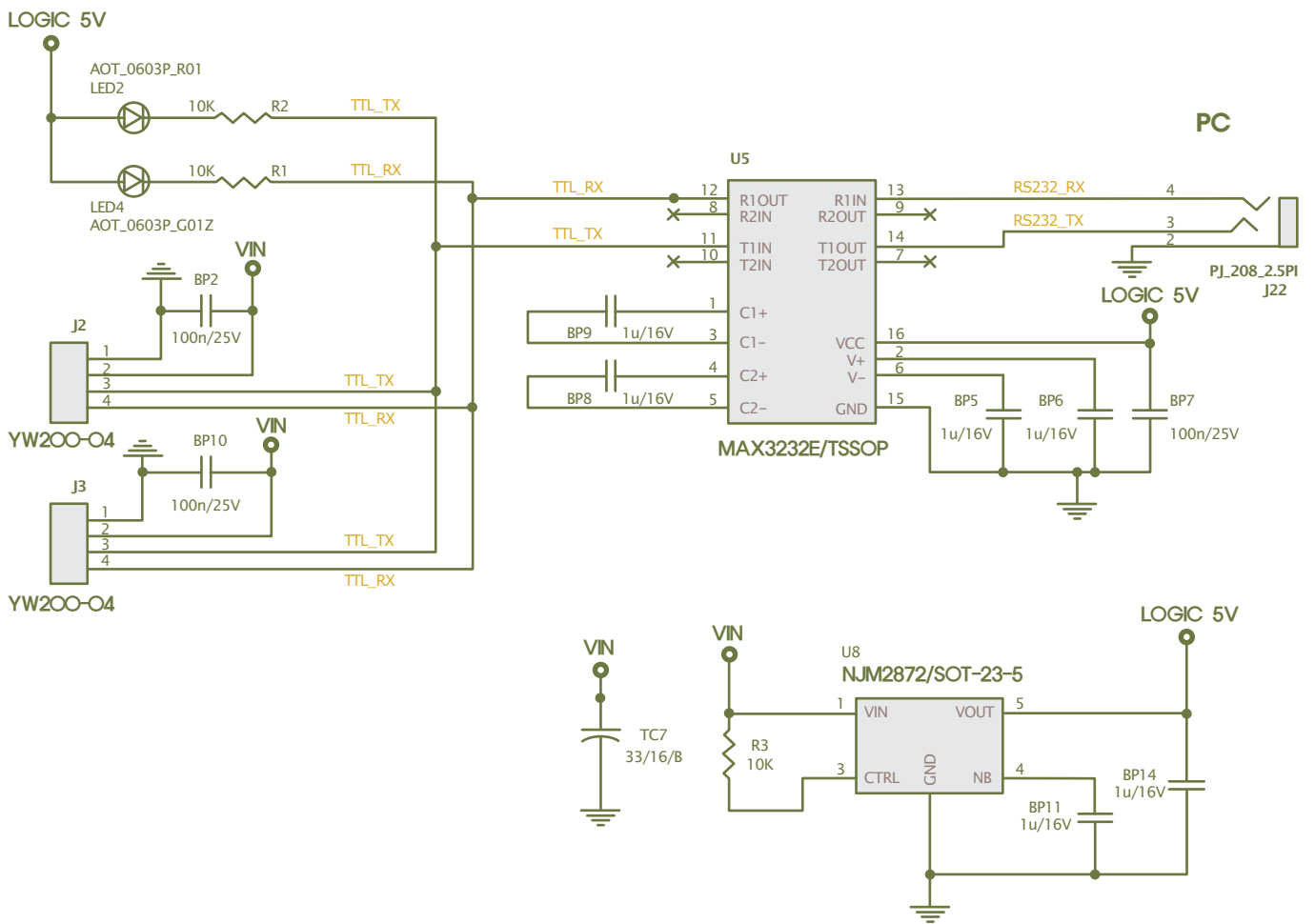

2.00mm (0.079") PITCH CONNECTOR



Wire-to-Board
Wafer

YW200 Series

DIP

Straight

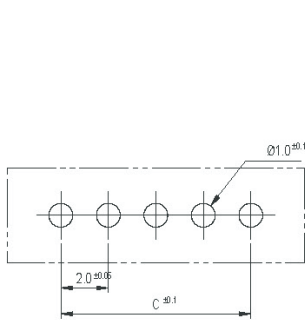
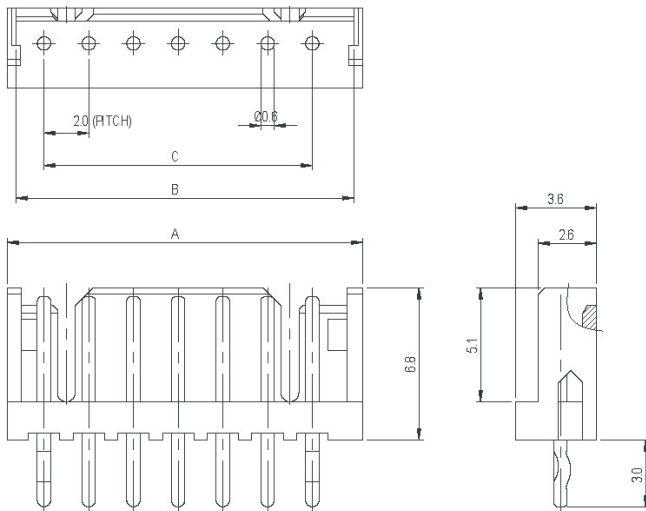
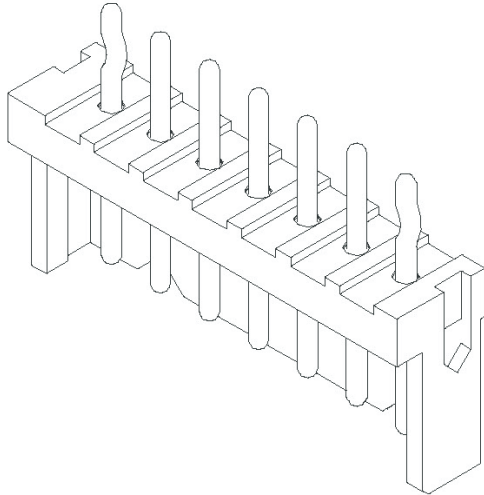

PCB LAYOUT

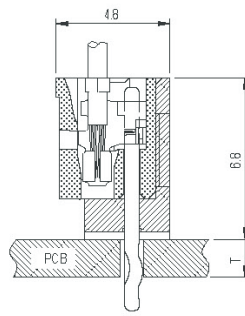

PCB ASS'Y

Material

I/NO	DESCRIPTION	TITLE	MATERIAL
1	WAFER	YW200	PA66, UL 94V Grade
2	PIN		Brass, Tin plated

Available Pin

PARTS NO.	A	B	C
YW200-02	5.9	5.1	2.0
YW200-03	7.9	7.1	4.0
YW200-04	9.9	9.1	6.0
YW200-05	11.9	11.1	8.0
YW200-06	13.9	13.1	10.0
YW200-07	15.9	15.1	12.0
YW200-08	17.9	17.1	14.0
YW200-09	19.9	19.1	16.0
YW200-10	21.9	21.1	18.0
YW200-11	23.9	23.1	20.0
YW200-12	25.9	25.1	22.0
YW200-13	27.9	27.1	24.0
YW200-14	29.9	29.1	26.0
YW200-15	31.9	31.1	28.0

Specification

ITEM	SPEC
Voltage Rating	AC/DC 125V
Current Rating	AC/DC 3A
Operating Temperature	-25°C~+85°C
Contact Resistance	30mΩ MAX
Withstanding Voltage	AC1000V/1min
Insulation Resistance	1000MΩ MIN
Applicable Wire	-
Applicable P.C.B	1.2~1.6mm
Applicable FPC/FFC	-
Solder Height	-
Crimp Tensile Strength	-
UL FILE NO	E108706

2.00mm (0.079") PITCH CONNECTOR

Wire-to-Board
Housing

YH200 Series

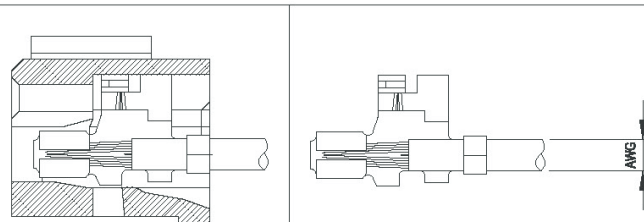
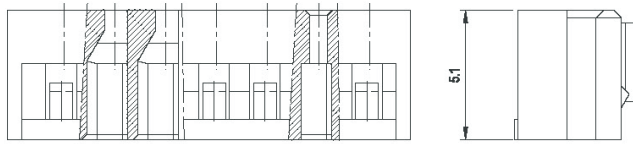
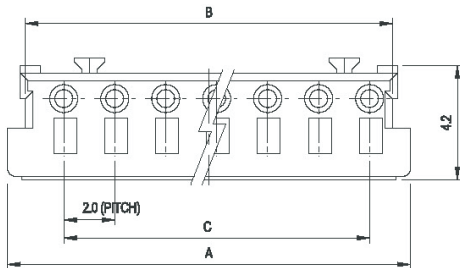
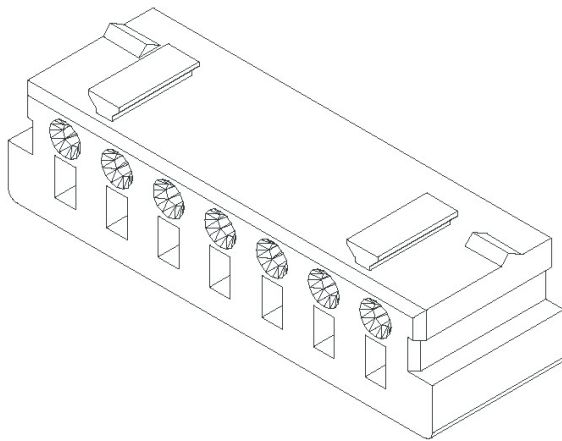

TERMINAL ASSEMBLY DRAWING

AWG: #22-#28

Material

I/NO	DESCRIPTION	TITLE	MATERIAL
1	HOUSING	YH200	PA66, UL 94V Grade

Available Pin

PARTS NO.	A	B	C
YH200-02	5.8	4.4	2.0
YH200-03	7.8	6.4	4.0
YH200-04	9.8	8.4	6.0
YH200-05	11.8	10.4	8.0
YH200-06	13.8	12.4	10.0
YH200-07	15.8	14.4	12.0
YH200-08	17.8	16.4	14.0
YH200-09	19.8	18.4	16.0
YH200-10	21.8	20.4	18.0
YH200-11	23.8	22.4	20.0
YH200-12	25.8	24.4	22.0
YH200-13	27.8	26.4	24.0
YH200-14	29.8	28.4	26.0
YH200-15	31.8	30.4	28.0

Specification

ITEM	SPEC
Voltage Rating	AC/DC 125V
Current Rating	AC/DC 3A
Operating Temperature	-25°C~+85°C
Contact Resistance	30mΩ MAX
Withstanding Voltage	AC1000V/1min
Insulation Resistance	1000MΩ MIN
Applicable Wire	AWG #24-#28
Applicable P.C.B	-
Applicable FPC/FFC	-
Solder Height	-
Crimp Tensile Strength	-
UL FILE NO	E108706

Application Terminal : YT200 (119 page)



HerkuleX DRS-0602 User Manual

Publisher : Dongbu Robot Co., Ltd
Address : 11th Fl Bucheon Techno Prk Bldg, 401, Yakdae-dong,
Wonmi-gu, Bucheon-si, Gyeonggi-do, S Korea
Customer Inquiry : 032-329-5551
FAX : 032-329-5569

No portion of this publication may be reproduced or transmitted
in any form without prior written authorization from Dongbu Robot Co., Ltd.

Dongbu Robot Co.,Ltd All rights reserved



KCC-REM-DB6
-DRS-0602