

### Features and Benefits

- ❑ High resolution and dynamic range
- ❑ Both digital (SPI) and analog outputs
- ❑ Low acceleration and angular rate cross sensitivity
- ❑ Low zero rate output drift
- ❑ Cost effective and compact solution
- ❑ High-performance MEMS sensor in mono crystalline Si yielding a superior long-term behavior reliability and dynamic range
- ❑ Programmable bandwidth
- ❑ Built-in on demand and non disruptive continuous self tests
- ❑ Factory set full scale range ( $\pm 300$  °/s)
- ❑ On chip EEPROM calibration
- ❑ Serial Number in EEPROM
- ❑ Small footprint (SMD CLCC32) with horizontal mounting
- ❑ Operating temperature range:  $-40^{\circ}\text{C}$  to  $85^{\circ}\text{C}$

### Application

- ❑ Vehicle rollover
- ❑ Robots

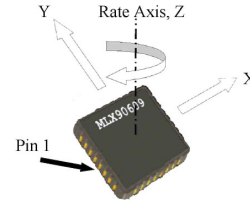

### Ordering Information

Part No.	Temperature Code	Package Code	Option code
MLX90609EEA-R2	E ( $-40^{\circ}\text{C}$ to $85^{\circ}\text{C}$ )	EA (CLCC32)	R2

### 1 Functional diagram

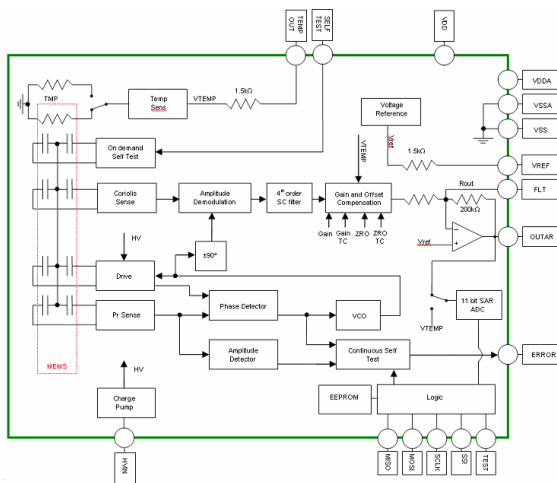

### 2 General Description

The MLX90609-R2 Angular Rate Sensor is a full gyroscopic system. A single SMD package contains a high performance Silicon micro machined sensor with signal conditioning circuitry. It operates from 5V supply and is designed for demanding automotive applications.

The MLX90609 delivers two output signals proportional to the angular rate perpendicular to the assembly surface. One of the output signals is in an analog voltage format (the output is 2.5V at zero angular rate and the full scale angular rate produces an output of 4.5V or 0.5V depending on direction of rotation) and the other one is in a digital SPI format.

***Table of Contents***

1 Functional diagram .....	1
2 General Description .....	1
3 Pin definitions and descriptions.....	3
4 MLX90609 Sensor Specific Specifications.....	4
5 Application example .....	5
6 Standard information regarding manufacturability of Melexis products with different soldering processes .....	6
7 ESD Precautions.....	7
8 Package information .....	7
9 Disclaimer .....	8

### 3 Pin definitions and descriptions

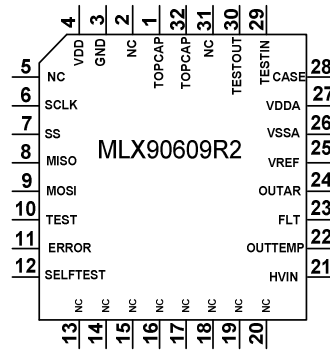

Figure 3-1 MLX90609 pin-out

	Pin Name	Function
Power Supply Pins	VSS	Digital ground 0V
	VDD	Digital 5V
	VDDA	Analog Supply 5V
	VSSA	Analog ground, 0V, externally tied to digital ground
Serial Communication Pins	SCLK	Clock for serial data transfer, In, digital
	MISO	Master In, Slave Out
	MOSI	Master Out, Slave In
	SS	Slave/Chip select (active low)
Factory Test Pins	TEST	Test-mode control pin (internal pull-down, In application tight to ground for EMC reasons)
	TESTIN	Do not connect
	TESTOUT	Do not connect
User Diagnostic Pins	SELFTEST	User on request self test of the secondary mode
	ERROR	Diagnostic output, continuous self test of the primary mode
Output Pins	OUTAR	Analog angular rate output
	OUTTEMP	Analog output of the temperature sensing module
General purpose pins	VREF	2.5V Output reference voltage
	HVIN	High voltage filter capacitor
	FLT	External capacitor for bandwidth setting
	TOPCAP	Tie to analog ground
	CASE	Tie to analog ground
	NC	Do not connect
	FLT	External capacitor for bandwidth setting

Table 3: MLX90609 Pin description

#### 4 MLX90609 Sensor Specific Specifications

DC Operating Parameters  $T_A = -40\text{ }^\circ\text{C}$  to  $85\text{ }^\circ\text{C}$ ,  $V_{DD} = 4.75\text{V}$  to  $5.25\text{V}$  (unless otherwise specified)

Parameter	Symbol	Test Conditions	Min	Typ	Max	Units
Output full scale (on OUTAR pin)	$FS_{OUT} = U_{OUT,\Omega\max}$ $-U_{OUT,\Omega\min}$			4		V
Full Scale Range	FS <sub>in</sub>	Factory set		±300		°/s
Linearity		Output, best fit based			+/- 0.5	% FS <sub>OUT</sub>
Initial Scale Factor (sensitivity)	$S_0 = \frac{FS_{OUT}}{FS_{IN}}$	According to Full Scale Range Setting. At 25°C, V <sub>dd</sub> =5V.		6.67		mV/°/sec
Scale Factor drift (sensitivity drift)		-40...+85°C temperature range supply voltage variation included	-5		5	%S <sub>0</sub>
Zero Rate Output (Bias)	ZRO	at 25°C, V <sub>dd</sub> =5V		2.5		V
Zero Rate Temperature drift (Bias drift)		-40...+85°C temperature range, V <sub>dd</sub> =5V	-5	0	5	% FS <sub>OUT</sub>
Zero Rate Supply Drift		4.75..5.25V at 25°C		250		mV/V
Bandwidth (-3 dB)		Selectable by external capacitor (see ch 5-application example)			75	Hz
FLT to OUTAR capacitor value		7 Hz Bandwidth (-4.5 to -1 dB)		100±5%		nF
Output Noise power spectral density		At 25°C		0.03		°/sec/√Hz
Angular Rate Cross-sensitivity for 0x,0y		for a full-scale angular rate along 0x,0y		1	2	%FS <sub>OUT</sub>
Resonance Frequency				8.2		KHz

Table 5: Sensor Specific specifications

## 5 Application example

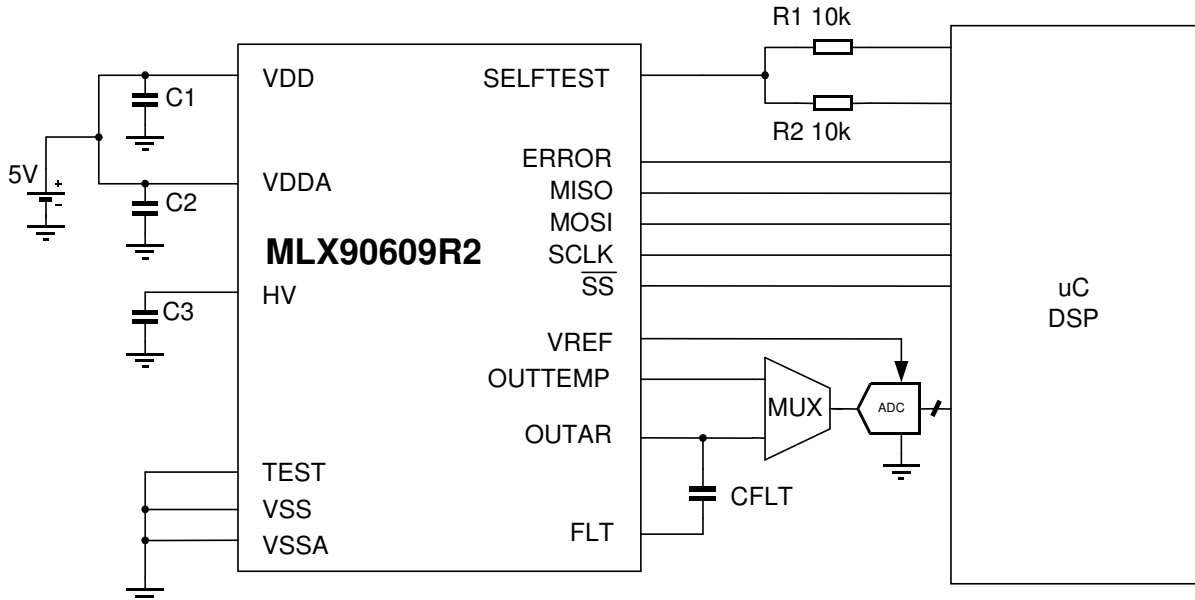

The MLX90609-R2 can simultaneously output analog and digital signals.

### Notes:

1.  $C_{FLT}$  implements a first order low pass filter cascaded with an internal 4-th order SC filter .

The  $-3dB$  bandwidth set by  $C_{FLT}$  is :

$f_{OUT} = 0.16 / (R_{OUT} * C_{FLT})$ , with  $R_{OUT} = 200k\Omega$  (typ)

It is recommended to use  $C_{FLT}$  even if the cut-off frequency is not specified to reduce switching spikes at the output.

2. It is recommended to use X5R or X7R type capacitors. Min. voltage for C3 should be 25V or more, and 10V or more for the other capacitors. Recommended values of decoupling capacitors C1 and C2 are 1.0 $\mu$ F and 0.1 $\mu$ F for C3. These capacitors should be placed as close as possible to their respective pins.

3. In normal operation mode the SELFTEST pin has to be in "HIGH" state and the bits SFT0 and SFT1 have to be cleared.

4. HVIN is a high impedance node. Be sure that an equivalent leakage resistance at this node isn't less than 2M $\Omega$

The analog output signal can be fed to a micro processor ( $\mu$ P) that contains an analog-to-digital converter. A multiplexer can be used to select between the temperature and the angular rate signals. The MLX90609 generates an internal reference voltage used for supplying the ADC, thereby maintaining accuracy regardless of the supply voltage of the  $\mu$ P.

Whilst supplying the analog output signal, the MLX90609 can simultaneously send a digital output signal to the  $\mu$ P. The MISO (Master input slave output) pin can be used to send a digital value of the angular rate as well as the temperature.

The micro processor can communicate with the device to get for example information about the reliability of the output signal. The Error pin is used by the MLX90609 to communicate to the  $\mu$ P that the angular rate signal is unreliable. The  $\mu$ P can request a test of the functionality of the Gyro

by using the SelfTest pin or sending the appropriate SPI command.

The MOSI (Master output slave input) pin can be used to write some data to the EEPROM of the MLX90609 (like for example writing an ID number). The  $\mu$ P uses the  $\overline{SS}$  pin to select the slave with which it wants to communicate. The  $\mu$ P uses the SCLK pin to send the clock for the serial data transfer. The bandwidth of the MLX90609 can be selected by connecting an appropriate capacitor in the FLT pin.

## **6 Standard information regarding manufacturability of Melexis products with different soldering processes**

Our products are classified and qualified regarding soldering technology, solderability and moisture sensitivity level according to following test methods:

### **Reflow Soldering SMD's (Surface Mount Devices)**

- IPC/JEDEC J-STD-020  
Moisture/Reflow Sensitivity Classification for Nonhermetic Solid State Surface Mount Devices (classification reflow profiles according to table 5-2)
- EIA/JEDEC JESD22-A113  
Preconditioning of Nonhermetic Surface Mount Devices Prior to Reliability Testing (reflow profiles according to table 2)

### **Wave Soldering SMD's (Surface Mount Devices) and THD's (Through Hole Devices)**

- EN60749-20  
Resistance of plastic- encapsulated SMD's to combined effect of moisture and soldering heat
- EIA/JEDEC JESD22-B106 and EN60749-15  
Resistance to soldering temperature for through-hole mounted devices

### **Iron Soldering THD's (Through Hole Devices)**

- EN60749-15  
Resistance to soldering temperature for through-hole mounted devices

### **Solderability SMD's (Surface Mount Devices) and THD's (Through Hole Devices)**

- EIA/JEDEC JESD22-B102 and EN60749-21  
Solderability

For all soldering technologies deviating from above mentioned standard conditions (regarding peak temperature, temperature gradient, temperature profile etc) additional classification and qualification tests have to be agreed upon with Melexis.

The application of Wave Soldering for SMD's is allowed only after consulting Melexis regarding assurance of adhesive strength between device and board.

Melexis is contributing to global environmental conservation by promoting **lead free** solutions. For more information on qualifications of **RoHS** compliant products (RoHS = European directive on the Restriction Of the use of certain Hazardous Substances) please visit the quality page on our website:

<http://www.melexis.com/quality.asp>

### 7 ESD Precautions

Electronic semiconductor products are sensitive to Electro Static Discharge (ESD). Always observe Electro Static Discharge control procedures whenever handling semiconductor products.

### 8 Package information

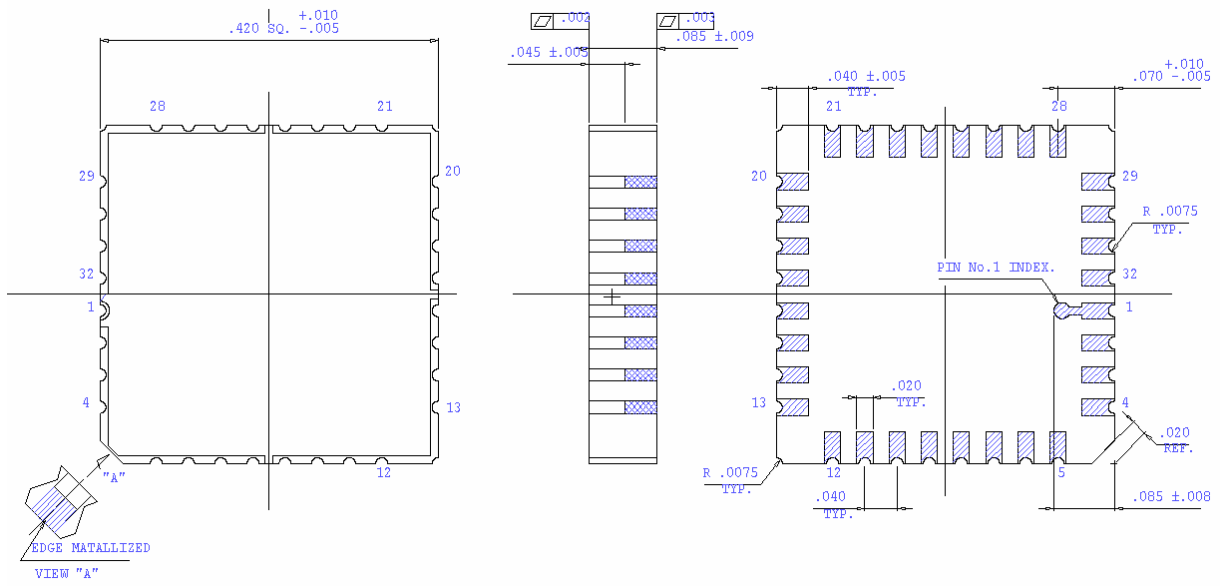

## **9 Disclaimer**

Devices sold by Melexis are covered by the warranty and patent indemnification provisions appearing in its Term of Sale. Melexis makes no warranty, express, statutory, implied, or by description regarding the information set forth herein or regarding the freedom of the described devices from patent infringement. Melexis reserves the right to change specifications and prices at any time and without notice. Therefore, prior to designing this product into a system, it is necessary to check with Melexis for current information. This product is intended for use in normal commercial applications. Applications requiring extended temperature range, unusual environmental requirements, or high reliability applications, such as military, medical life-support or life-sustaining equipment are specifically not recommended without additional processing by Melexis for each application.

The information furnished by Melexis is believed to be correct and accurate. However, Melexis shall not be liable to recipient or any third party for any damages, including but not limited to personal injury, property damage, loss of profits, loss of use, interrupt of business or indirect, special incidental or consequential damages, of any kind, in connection with or arising out of the furnishing, performance or use of the technical data herein. No obligation or liability to recipient or any third party shall arise or flow out of Melexis' rendering of technical or other services.

© 2005 Melexis NV. All rights reserved.

For the latest version of this document, go to our website at  
**[www.melexis.com](http://www.melexis.com)**

Or for additional information contact Melexis Direct:

<b>Europe, Africa, Asia:</b>	<b>America:</b>
Phone: +32 1367 0495	Phone: +1 603 223 2362
E-mail: <a href="mailto:sales_europe@melexis.com">sales_europe@melexis.com</a>	E-mail: <a href="mailto:sales_usa@melexis.com">sales_usa@melexis.com</a>

ISO/TS 16949 and ISO14001 Certified